

HP 37718A  
HP 37719A  
Installation and  
Verification  
Manual

HP OmniBER 718/719

---

© Copyright Hewlett-Packard Ltd.1999

All rights reserved.  
Reproduction, adaption, or translation without prior written permission is prohibited, except as allowed under the copyright laws.

HP Part No. 37718-90069

First Edition, May 99

Printed in U.K.

## **Documentation Warranty**

The information contained in this document is subject to change without notice.

*Hewlett-Packard makes no warranty of any kind with regard to this material, including, but not limited to, the implied warranties or merchantability and fitness for a particular purpose.*

Hewlett-Packard shall not be liable for errors contained herein or for incidental or consequential damages in connection with the furnishing, performance, or use of this material.

## **WARNING**

For details of safety, see Safety information in this manual.

**HP Part Number 37718-90069**

**Printed in U.K. May 1999**

---

**HP OmniBER 718/719**



## **1 General Information**

### Warranty 1-1

Responsibilities of the Customer 1-2

Certification 1-3

Assistance 1-3

Notice 1-3

Restricted Rights Legend 1-3

### Instruments Covered By Manual 1-4

### Storage and Shipment 1-4

Repackaging for Shipment 1-4

### Weight and Dimensions 1-5

### Safety Precautions for the Operator 1-6

Lifting/Carrying the HP 37718A/19A 1-6

Safety Symbols 1-7

### Operators Maintenance 1-8

Cleaning 1-8

Power Supply Fuse Replacement 1-9

### Statement of Compliance 1-10

Australian EMC Regulations 1-10

Noise Declaration (German) 1-10

### Electromagnetic Compatibility 1-11

Electrostatic Discharge 1-11

## **2 Installation**

### Initial Inspection 2-1

### Operating Environment 2-2

### Preparation for Use 2-3

Power Requirements 2-3

Fuses 2-3

Fuse Replacement 2-3

- Connecting to the Power Supply 2-4
- Connecting to the Network 2-6**
  - All Connectors 2-6
  - Electrical Interface Connectors 2-6
  - Optical Interface Connectors 2-9
- Connecting Accessories 2-11**
  - 10 Base-T Lan Connection Radiated Emissions 2-11
  - Hewlett-Packard Interface Bus 2-12
- Additional Precautions for Service Engineers 2-14**
  - Safety Precautions 2-14
  - ESD Precautions 2-14
  - Front Panel Soft Recovery (Cold Start) 2-16

### **3 Performance Tests**

- Introduction 3-1
- Equipment Required 3-1
- Performance Test Record 3-1
- Calibration Cycle 3-1
- Option Configuration 3-1
- Recall Default Settings 3-4
- Self Test 3-5**
- PDH/DSn Internal Transmitter Clock Accuracy & Offset 3-10**
  - Specifications 3-10
  - Equipment Required 3-10
  - E1 (2.048Mb/s) Frequency Accuracy 3-11
  - E2 (8.448Mb/s) Frequency Accuracy 3-12
  - E3 (34.368Mb/s) Frequency Accuracy 3-12
  - E4 (139.264Mb/s) Frequency Accuracy 3-13
  - DS1 (1.544Mb/s) Frequency Accuracy 3-13
  - DS3 (44.736Mb/s) Frequency Accuracy 3-14
- PDH/DSn Transmitter Output 3-15**

Specification	3-15
Equipment Required	3-16
Procedure - 34.368 Mb/s	3-19
Procedure - 8.448 Mb/s	3-21
Procedure - 2.048 Mb/s	3-23
Procedure - DSX-3	3-26
Procedure - DSX-1	3-28
<b>PDH/DSn Receiver Equalization</b>	<b>3-32</b>
Specifications	3-32
Description	3-32
Equipment Required	3-32
Procedure	3-33
<b>PDH/DSn Receiver Monitor Levels</b>	<b>3-39</b>
Specifications	3-39
Description	3-39
Equipment Required	3-39
<b>External Mux/Demux</b>	<b>3-44</b>
Specifications	3-44
Description	3-44
Equipment Required	3-44
<b>PDH/DSn Frequency Measurement and Looped Clock</b>	<b>3-54</b>
Specifications	3-54
Equipment Required	3-54
<b>SDH/SONET Transmitter Clock Accuracy</b>	<b>3-58</b>
Specification	3-58
Description	3-58
Equipment Required	3-58
Procedure	3-58
<b>External Clock/Data Reference Inputs &amp; Clock Reference Output</b>	<b>3-59</b>
Specifications	3-59
<b>SDH/SONET Frequency Offsets</b>	<b>3-64</b>
Specifications	3-64

Description	3-64
Equipment Required	3-64
Procedure	3-64
<b>STM-0/STS-1 Transmitter Output Waveshape</b>	<b>3-66</b>
Specifications	3-66
Description	3-66
Equipment Required	3-66
Procedure	3-66
<b>STM-1/STS-3 Transmitter Output Waveshape</b>	<b>3-70</b>
Specifications	3-70
Description	3-70
Equipment Required	3-70
Procedure	3-70
<b>SDH/SONET Receiver Equalization</b>	<b>3-75</b>
Specifications	3-75
Equipment Required	3-75
Procedure	3-77
<b>SDH/SONET Receiver Monitor Levels</b>	<b>3-78</b>
Specifications	3-78
Description	3-78
Equipment Required	3-78
Procedure	3-78
<b>Multirate Optical Interfaces</b>	<b>3-82</b>
Specification (1310 nm Transmitter)	3-82
Specification (1550 nm Transmitter)	3-82
Specification (Receiver)	3-82
Description	3-83
Equipment Required	3-83
<b>PDH Transmit/Receive Jitter Amplitude Accuracy</b>	<b>89</b>
Specifications	89
Description	89
Equipment Required	89
Procedure	90



TX/RX Jitter Accuracy Test Setup, Ranges (1/1.6 UIp-p)	93
External Jitter Generation and Demod Output	98
<b>SDH Transmit/Receive Jitter Amplitude Accuracy</b>	<b>101</b>
Specifications	101
Description	101
Equipment Required	102
Procedure	103
External Jitter Generation and Demod Output	117
Performance Test Record	121
Jitter Performance Test Record (options 204, 205 & 206)	131

## **4 Terms**

ETSI/ANSI Conversion and Equivalent Terms	4-1
---	-----

## **5 Self Test Overview**

Self Tests	5-1
OVERALL FUNCTION SELF TESTS	5-1
All Tests (test time - up to 1 Hour depending on options)	5-2
SPECIFIC MEASUREMENT HARDWARE/FUNCTION TESTS	5-2
PDH Test (test time- approximately 20 minutes)	5-3
BER Test (test time- approximately 20 minutes)	5-4
JITTER Test (test time- approximately 20 minutes)	5-6

## **6 Option Structure/Module Configuration**

Option Structure/Module Configuration	6-1
---------------------------------------	-----



# 1

## General Information

---

### **Warranty**

HP PRODUCT

DURATION OF WARRANTY

HP 37718A/19A

3 years

- 1 HP warrants HP hardware, accessories and supplies against defects in materials and workmanship for the period specified above. If HP receives notice of such defects during the warranty period, HP will, at its option, either repair or replace products which prove to be defective. Replacement products may be either new or like-new.
- 2 HP warrants that HP software will not fail to execute its programming instructions, for the period specified above, due to defects in material and workmanship when properly installed and used. If HP receives notice of such defects during the warranty period, HP will replace software media which does not execute its programming instructions due to such defects.
- 3 HP does not warrant that the operation of HP products will be uninterrupted or error free. If HP is unable, within a reasonable time, to repair or replace any product to a condition as warranted, customer will be entitled to a refund of the purchase price upon prompt return of the product.
- 4 HP products may contain remanufactured parts equivalent to new in performance or may have been subject to incidental use.
- 5 The warranty period begins on the date of delivery or on the date of installation if installed by HP. If customer schedules or delays HP installation more than 30 days after delivery, warranty begins on the 31st day from delivery.
- 6 Warranty does not apply to defects resulting from (a) improper or inadequate maintenance or calibration, (b) software, interfacing, parts or supplies not supplied by HP, (c) unauthorized modification or misuse, (d) operation outside of the published environmental specifications for the product, or (e) improper site preparation or maintenance.

## General Information

### **Warranty**

- 7 TO THE EXTENT ALLOWED BY LOCAL LAW, THE ABOVE WARRANTIES ARE EXCLUSIVE AND NO OTHER WARRANTY OR CONDITION, WHETHER WRITTEN OR ORAL, IS EXPRESSED OR IMPLIED AND HP SPECIFICALLY DISCLAIMS ANY IMPLIED WARRANTIES OR CONDITIONS OF MERCHANTABILITY, SATISFACTORY QUALITY, AND FITNESS FOR A PARTICULAR PURPOSE.
- 8 HP will be liable for damage to tangible property per incident up to the greater of \$300,000 or the actual amount paid for the product that is the subject of the claim, and for damages for bodily injury or death, to the extent that all such damages are determined by a court of competent jurisdiction to have been directly caused by a defective HP product.
- 9 TO THE EXTENT ALLOWED BY LOCAL LAW, THE REMEDIES IN THIS WARRANTY STATEMENT ARE CUSTOMER'S SOLE AND EXCLUSIVE REMEDIES. EXCEPT AS INDICATED ABOVE, IN NO EVENT WILL HP OR ITS SUPPLIERS BE LIABLE FOR LOSS OF DATA OR FOR DIRECT, SPECIAL, INCIDENTAL, CONSEQUENTIAL (INCLUDING LOST PROFIT OR DATA), OR OTHER DAMAGE, WHETHER BASED IN CONTRACT, TORT, OR OTHERWISE.

FOR CONSUMER TRANSACTIONS IN AUSTRALIA AND NEW ZEALAND: THE WARRANTY TERMS CONTAINED IN THIS STATEMENT, EXCEPT TO THE EXTENT LAWFULLY PERMITTED, DO NOT EXCLUDE, RESTRICT OR MODIFY AND ARE IN ADDITION TO THE MANDATORY STATUTORY RIGHTS APPLICABLE TO THE SALE OF THIS PRODUCT TO YOU.

### **Responsibilities of the Customer**

The customer shall provide:

- 1 Access to the products during the specified periods of coverage to perform maintenance.
- 2 Adequate working space around the products for servicing by Hewlett-Packard personnel.
- 3 Access to and use of all information and facilities determined necessary by Hewlett-Packard to service and/or maintain the products. (Insofar as these items may contain proprietary or classified information, the customer shall assume full responsibility for

## General Information

### **Warranty**

safeguarding and protection from wrongful use.)

- 4 Routine operator maintenance and cleaning as specified in the Hewlett-Packard Operating and Service Manuals.
- 5 Consumables such as paper, disks, magnetic tapes, ribbons, inks, pens, gases, solvents, columns, syringes, lamps, septa, needles, filters, frits, fuses, seals, detector flow cell windows, etc.

### **Certification**

Hewlett-Packard Company certifies that this product met its published specifications at the time of shipment from the factory. Hewlett-Packard further certifies that its calibration measurements are traceable to the United States National Bureau of Standards, to the extent allowed by the Bureau's calibration facility and to the calibration facilities of other International Standards Organization members!

### **Assistance**

Product maintenance agreements and other customer assistance agreements are available for Hewlett-Packard products.

### **Notice**

The information contained in this document is subject to change without notice.

Hewlett-Packard shall not be liable for errors contained herein or for incidental or consequential damages in connection with the furnishing, performance or use of this material.

This document contains proprietary information which is protected by copyright. All rights are reserved. No part of this document may be photocopied or reproduced without the prior written consent of the manufacturer, Hewlett-Packard Ltd.

### **Restricted Rights Legend**

Use, duplication, or disclosure by the government is subject to restrictions as set forth in subdivision (b)(3)(ii) of the Rights in Technical Data and Computer Software clause at 52.227-7013. Hewlett-Packard Company; 3000 Hanover Street; Palo Alto, California 94304.

## Instruments Covered By Manual

Attached to the rear panel of the instrument is a serial number plate. The serial number plate has a two letter reference denoting country of origin (GB = Great Britain) and an eight digit serial number. The serial number is unique to each instrument and should be quoted in all correspondence with Hewlett-Packard, especially when ordering replacement parts. Refer to Chapter 6 for instrument options covered.



### Serial Number Plate

---

## Storage and Shipment

The instrument may be stored or shipped in environments within the following limits:

- Temperature** -20° C to +70° C  
-15° C to +50° C with lid printer
- Altitude** Up to 15,200 meters (50,000 feet)

The instrument should also be protected from temperature extremes which could cause condensation within the instrument.

## Repackaging for Shipment

**Tagging for Service.** If the instrument is being returned to Hewlett-Packard for service, please complete a repair tag and attach it to the instrument.

## General Information

### Weight and Dimensions

**Original Packaging.** Containers and materials identical to those used in factory packaging are available from Hewlett-Packard offices. If the instrument is being returned to Hewlett-Packard for servicing, attach a tag indicating the type of service required, return address, model number, and full serial number. Mark the container FRAGILE to ensure careful handling. In any correspondence, refer to the instrument by model number and full serial number.

**Other Packaging.** The following general instructions should be followed when repackaging with commercially available materials:

- Wrap instrument in heavy paper or plastic. If the instrument is being shipped to Hewlett-Packard, attach a tag indicating the type of service required, return address, model number and full serial number.
- Use a strong shipping container. A double wall carton made of 350 pound test material is adequate.
- Use a layer of shock absorbing material 70 to 100 mm (3 to 4 inch) thick, around all sides of the instrument to provide firm cushioning and prevent movement inside the container. Protect the Front Panel controls and Rear Panel connectors with cardboard.
- Seal shipping container securely.
- Mark shipping container FRAGILE to ensure careful handling.
- In any correspondence, refer to instrument by model number and full serial number.

---

## Weight and Dimensions

**Weight:** 18 kg (40 lb) fully loaded

**Dimensions:** 190mm (7.5in) high, 340mm (14in) wide, 420mm (17in) deep (including cover).

## **Safety Precautions for the Operator**

The following general safety precautions must be observed during all phases of operation, service, and repair of this instrument. Failure to comply with these precautions or with specific warnings elsewhere in this manual violates safety standards of design, manufacture, and intended use of the instrument. Hewlett-Packard Company assumes no liability for the customer's failure to comply with these requirements.

In particular, the operator should note the following safety information:

- “Safety Symbols” on page 1-7
- “Connecting to the Power Supply” on page 2-4
- “Operating Environment” on page 2-2
- “Fuse Replacement” on page 2-3
- “Operators Maintenance” on page 1-8
- “Lifting/Carrying the HP 37718A/19A” on page 1-6

**DO NOT** operate damaged equipment: Whenever it is possible that the safety protection features built into this product have been impaired, either through physical damage, excessive moisture, or any other reason, REMOVE POWER and do not use the product until safe operation can be verified by service-trained personnel. If necessary, return the product to a Hewlett-Packard Sales and Service Office for service and repair to ensure the safety features are maintained.

### **Lifting/Carrying the HP 37718A/19A**

Before attempting to lift or carry the instrument consider the following basic lifting techniques to help avoid personal injury.

#### **Using both arms to lift instrument.**

- Reach for the instrument - bend your knees and waist, and keep your back straight.
- GRASP the instrument firmly.
- LIFT with your legs.
- KEEP your shoulders level.



## Safety Precautions for the Operator

### Safety Symbols

The following symbols on the instrument and in the manual indicate precautions which must be taken to maintain safe operation of the instrument



The Instruction Documentation Symbol. The product is marked with this symbol when it is necessary for the user to refer to the instructions in the supplied documentation.



Indicates the field wiring terminal that must be connected to earth ground before operating the equipment - protects against electrical shock in case of fault.

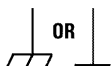

Frame or chassis ground terminal - typically connects to the equipment's metal frame.



Alternating current (AC)



Direct current (DC)



Indicates hazardous voltages

**WARNING**

Warning denotes a hazard. It calls attention to a procedure, which if not correctly performed or adhered to could result in injury or loss of life. Do not proceed beyond a warning note until the indicated conditions are fully understood and met.

**CAUTION**

Caution denotes a hazard. It calls attention to a procedure, which if not correctly performed or adhered to could result in damage to or destruction of the instrument. Do not proceed beyond a warning note until the indicated conditions are fully understood and met.



Indicates that a laser is fitted. The user must refer to the manual for specific Warning or Caution information to avoid personal injury or damage to the product.

## **Operators Maintenance**

---

### **WARNING**

---

**NO OPERATOR SERVICEABLE PARTS INSIDE. REFER SERVICING TO QUALIFIED PERSONNEL. TO PREVENT ELECTRICAL SHOCK DO NOT REMOVE COVERS.**

Maintenance appropriate for the operator is:

- Cabinet cleaning
- Optical Connector Cleaning
- Power supply fuse replacement
- Ensure ventilating fan cover is clean.

### **Cleaning**

#### **Cabinet Cleaning**

Clean the cabinet using a dry cloth only.

#### **Optical Connector Cleaning**

It is recommended that the optical connectors be cleaned at regular intervals using the following materials:

<b>Description</b>	<b>HP Part Number</b>
Blow Brush	9300-1131
Isopropyl Alcohol	8500-5344
Lens Cleaning Paper	9300-0761
Adhesive Tape Kit	15475-68701

---

### **CAUTION**

---

Do not insert any tool or object into the IN or OUT ports of the instrument as damage to or contamination of the optical fibre may result.

- 1 Recall Default settings (STORED SETTINGS 0) and remove the

## General Information

### **Operators Maintenance**

power from the HP 37718A/19A.

- 2 Remove the adapters from the IN and OUT ports.
- 3 Using the blow brush with the brush removed blow through the ferrule of the standard flexible connector and the adapter.

---

#### **CAUTION**

---

If the optical fibre of the fixed connector requires further cleaning this entails disassembly of the module which should only be carried out by suitably trained service personnel.

- 4 Apply some isopropyl alcohol to a piece of the cleaning paper and clean the barrel of the adapter. Using a new piece of cleaning paper, clean the face of the adapter. Repeat this operation, using a new piece of cleaning paper each time.
- 5 Lightly press the adhesive side of the tape provided against the front of the adapter, then remove it quickly - repeat twice. This removes any particles of cleaning paper which may be present.
- 6 Replace the adapters on the flexible connector.

### **Power Supply Fuse Replacement**

See "Fuse Replacement" on page 2-3

## **Statement of Compliance**

This instrument has been designed and tested in accordance with IEC Publication 1010-1 + A1:1992 Safety requirements for Electrical Equipment for Measurement, Control and Laboratory Use, and has been supplied in a safe condition. The instruction documentation contains information and warnings which must be followed by the user to ensure safe operation and to maintain the instrument in a safe condition.



The CE mark shows that the product complies with all relevant European legal Directives.

**ISM 1-A**

This is a symbol of an Industrial Scientific and Medical Group 1 Class A product.



The CSA mark is a registered trademark of the Canadian Standards Association.

### **Australian EMC Regulations**



The C-Tick mark is a registered trademark of the Spectrum Management Agency of Australia. This signifies compliance with the Australian EMC Framework Regulations under the terms of the Radiocommunications Act of 1992.

### **Noise Declaration (German)**

LpA<70dB

am Arbeitsplatz (operator position)  
normaler Betrieb (normal position)  
nach DIN 45635 pt.19 (per ISO 7779)

## **Electromagnetic Compatibility**

This product has been designed to meet the protection requirements of the European Communities Electromagnetic Compatibility (EMC) directives:

- EN55011:1991 (Group 1, Class A)
- EN50082-1:1992
- IEC 1000-4-2 (1995) ESD
- IEC 1000-4-3 (1995) Radiated Susceptibility
- IEC 1000-4-4 (1995) EFT

In order to preserve the EMC performance of the product, any cable which becomes worn or damaged must be replaced with the same type and specification.

## **Electrostatic Discharge**

When an air discharge is applied to the HP 37718A/19A in accordance with IEC 801-2 (1991), degradation in performance may be observed in the form of occasional bit errors being counted.

See also “10 Base-T Lan Connection Radiated Emissions” on page 2-11

General Information  
**Electromagnetic Compatibility**

**Declaration of Conformity**  
according to ISO/IEC Guide 22 and EN45014

**Manufacturer's Name:** Hewlett Packard Ltd.  
**Manufacturer's Address:** Telecomms Networks Test Division  
South Queensferry  
West Lothian, EH30 9TG  
Scotland, United Kingdom

Declares that the product

**Product Name:** Communications performance Analyzer  
**Model Numbers:** HP 37718A  
**Product Options:** This declaration covers all options of the above products as detailed in TCF A-5951-9852-01

Conforms with the protection requirements of European Council Directive 89/336/EEC on the approximation of the laws of the member states relating to electromagnetic compatibility.

Against EMC test specifications EN 55011:1991 (Group 1, Class A) and EN 50082-1:1992

**As Detailed in:** Electromagnetic Compatibility (EMC)  
Technical Construction File (TCF) No. A-5951-9852-01

**Assessed by:** Dti Appointed Competent Body  
EMC Test Centre,  
GEC-Marconi Avionics Ltd.,  
Maxwell Building,  
Donibristle Industrial Park,  
KY11 5LB  
Scotland, United Kingdom

Technical Report Number:6893/2200/CBR, dated 21 August 1997

**Supplementary Information:**

The product conforms to the following safety standards:

IEC 61010-1:1992  
EN 61010-1:1993  
CSA-C22.2 No. 1010 Series M-93  
EN 60825-1(1994) / IEC 825-1 (1993)

The product herewith complies with the requirements of the Low Voltage Directive 73/23/EEC, and carries the CE-marking accordingly.

*South Queensferry, Scotland*

*9 September 1998*



**Location**

**Date**

**W.R. Pearson / Quality Manager**

General Information  
**Electromagnetic Compatibility**

**Declaration of Conformity**  
according to ISO/IEC Guide 22 and EN45014

**Manufacturer's Name:** Hewlett Packard Ltd.

**Manufacturer's Address:** Telecomms Networks Test Division  
South Queensferry  
West Lothian, EH30 9TG  
Scotland, United Kingdom

Declares that the product

**Product Name:** Communications Performance Analyzer

**Model Numbers:** HP 37719A

**Product Options:** This declaration covers all options of the above products as detailed in TCF A-5951-9852-01

Conforms with the protection requirements of European Council Directive 89/336/EEC on the approximation of the laws of the member states relating to electromagnetic compatibility.

Against EMC test specifications EN 55011:1991 (Group 1, Class A) and EN 50082-1:1992

**As Detailed in:** Electromagnetic Compatibility (EMC)  
Technical Construction File (TCF) No. A-5951-9852-01

**Assessed by:** Dti Appointed Competent Body  
EMC Test Centre,  
GEC-Marconi Avionics Ltd.,  
Maxwell Building,  
Donibristle Industrial Park,  
KY11 5LB  
Scotland, United Kingdom

Technical Report Number:6893/2200/CBR, dated 21 August 1997

**Supplementary Information:**

The product conforms to the following safety standards:

IEC 61010-1:1992  
EN 61010-1:1993  
CSA-C22.2 No. 1010 Series M-93  
EN 60825-1(1994) / IEC 825-1 (1993)

The product herewith complies with the requirements of the Low Voltage Directive 73/23/EEC, and carries the CE-marking accordingly.

*South Queensferry, Scotland*

*9 September 1998*



**Location**

**Date**

**W.R. Pearson / Quality Manager**

General Information  
**Electromagnetic Compatibility**



## 2

# Installation

---

## Initial Inspection

---

**WARNING**

---

**TO AVOID HAZARDOUS ELECTRICAL SHOCK, DO NOT PERFORM ELECTRICAL TESTS WHEN THERE ARE SIGNS OF SHIPPING DAMAGE TO ANY PORTION OF THE OUTER ENCLOSURE (COVERS, PANELS, METERS).**

Inspect the shipping container for damage. If the shipping container or cushioning material is damaged, it should be kept until the contents of the shipment have been checked for completeness and the instrument has been checked both mechanically and electrically. Procedures for checking electrical operation are given in Chapter 3. If the contents of the shipment are incomplete, if there is mechanical damage or defect, notify the nearest Hewlett-Packard Office. If the instrument does not pass the electrical performance tests given in Chapter 3, notify the nearest Hewlett-Packard office. If the shipping container is also damaged, or the cushioning material shows signs of stress, notify the carrier as well as the nearest Hewlett-Packard office. Keep the shipping materials for the carrier's inspection. The Hewlett-Packard office will arrange for repair or replacement without waiting for claim settlement.

## **Operating Environment**

This instrument is designed for Indoor use only.

**DO NOT** operate the product in an explosive atmosphere or in the presence of flammable gasses or fumes.

This instrument may be operated in environments within the following limits:

**Temperature:** 0° C to +45° C  
+5° C to +40° C for Jitter operation.  
+5° C to +35° C with lid printer

**Altitude** up to 3050m (10,000ft)

**Humidity** up to 95% relative humidity to 40° C but it should be protected from temperature extremes which may cause condensation.

To ensure adequate cooling do not obstruct air vents in the instrument cabinet. Do not for example operate the instrument if it is standing on its rear feet, as air vents may be obstructed by floor covering.

---

**CAUTION**

---

This instrument is designed for use in Installation Category II and Pollution Degree 2 per IEC 1010 and 644 respectively.

---

**CAUTION**

---

**VENTILATION REQUIREMENTS:** When installing the instrument in a cabinet, the convection into and out of the instrument must not be restricted. If the total power dissipated in the cabinet is greater than 800 watts, then forced convection must be used.

---

---

## Preparation for Use

---

**WARNING**

---

**FOR CONTINUED PROTECTION AGAINST FIRE HAZARD REPLACE FUSE ONLY WITH SAME TYPE AND RATINGS (see “Fuses” on page 2-3).**

---

**WARNING**

---

**If this instrument is not used as specified, the protection provided by the equipment could be impaired. This instrument must be used in a normal condition only (in which all means for protection are intact).**

### Power Requirements

The HP 37718A/19A Communications Performance Analyzer requires a power source of 90 V to 132 V ac or 198 V to 264 V ac at a frequency between 47 Hz and 63 Hz (nominal).

Total power consumption is 450 VA (maximum).

The fuse rating for the power source is given in the following Table.

### Fuses

Line Voltage	Fuse Rating	HP Part Number
90V to 264V	5A Timed, 250V	2110-1120

### Fuse Replacement

Only the ac line fuse located at the rear of the instrument may be replaced by the operator.

---

**WARNING**

---

**ALL OTHER FUSE REPLACEMENT SHOULD ONLY BE CARRIED OUT BY SUITABLY TRAINED SERVICE PERSONNEL AWARE OF THE HAZARDS INVOLVED.**

Installation  
**Preparation for Use**

---

**WARNING**

**BEFORE REMOVING THE FUSE, THE AC LINE POWER CORD SHOULD BE DISCONNECTED FROM THE POWER SOURCE AND THE OTHER END DISCONNECTED FROM THE INSTRUMENT.**

---

---

**WARNING**

**ONLY USE A FUSE OF THE CORRECT RATING AS LISTED IN “Fuses” on page 2-3. DO NOT** use repaired fuses or short-circuited fuseholders: For continued protection against fire, replace the line fuse(s) only with fuse(s) of the same voltage and current rating and type.

---

The fuse is removed by inserting a suitable flat bladed tool into the slot in the fuse cap and turning counter-clockwise. The cap and the fuse can then be removed and the fuse changed for another of the correct rating. The fuse rating and HP part number are listed in “Fuses” on page 2-3.

### **Connecting to the Power Supply**

---

**WARNING**

**This is a Safety Class I instrument (provided with a protective earthing ground, incorporated in the powercord). The mains plug shall only be inserted in a socket outlet provided with a protective earth contact. Any interruption of the protective conductor inside or outside of the instrument is likely to make the instrument dangerous. Intentional interruption is prohibited.**

---

---

**CAUTION**

Before switching on this instrument, make sure that the line supply voltage is in the specified ranges. Range selection is automatic.

---

Installation  
Preparation for Use

**Power Cord**

---

**WARNING**

---

**TO AVOID THE POSSIBILITY OF INJURY OR DEATH, THE FOLLOWING PRECAUTIONS MUST BE FOLLOWED BEFORE THE INSTRUMENT IS SWITCHED ON:-**

---

**WARNING**

---

**(a) Note that the protection provided by grounding the instrument cabinet may be lost if any power cable other than the three-pronged type is used to couple the ac line voltage to the instrument.**

---

**WARNING**

---

**(b) If this instrument is to be energized via an auto-transformer to reduce or increase the line voltage, make sure that the common terminal is connected to the neutral pole of the power source.**

---



**WARNING**

---

**(c) The power cable plug shall only be inserted into a socket outlet provided with a protective ground contact. The protective action must not be negated by the use of an extension cord without a protective conductor (grounding).**

The power cord supplied with each instrument varies with the country of destination. The following figure illustrates the standard power plug and cord configurations that are commonly used. The part number shown beneath each plug is the part number of the appropriate power cord and plug. If the appropriate power cord is not included with the instrument notify the nearest Hewlett-Packard office and a replacement will be provided.

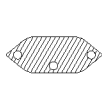
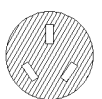
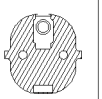
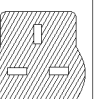
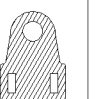
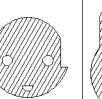
**Power Cord Configurations and Part Numbers**

						
8120-2104	8120-1369	8120-1689	8120-1351	8120-1378 US 8120-4753 JAP	8120-2956	8120-4211

## Connecting to the Network

The network connectors are located on the modules at the side of the instrument. The connections available depend on the options fitted to your instrument.

Before Connecting, note the Warning and Caution information given.

### All Connectors

---

#### CAUTION

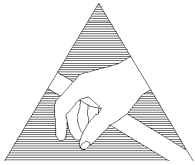

When connecting or disconnecting, ensure that you are grounded or, make contact with the metal surface of the Mainframe with your free hand to bring you, the module, and the mainframe to the same static potential.

Modules remain susceptible to ESD damage while the module is installed in the Mainframe

Additional ESD information is required when servicing see “Additional Precautions for Service Engineers” on page 2-14

### Electrical Interface Connectors

#### **RECEIVER** **2,8,34,140 IN**

PDH receiver input interface. Allows the connection of 75  $\Omega$  unbalanced data signals (all rates) and 120  $\Omega$  balanced data signals at 2 Mb/s.

#### **TRANSMIT** **2,8,34,140 OUT**

PDH transmitter output interface. Provides 75  $\Omega$  unbalanced data output (all rates) and 120  $\Omega$  balanced data output at 2 Mb/s

#### **DS3, 2Mb/s,** **34Mb/s 75 $\Omega$ IN**

PDH/DSn receiver input interface. Allows the connection of 75 $\Omega$  unbalanced DS3, 2 Mb/s and 34.368 Mb/s data signals.

#### **DS3, 2Mb/s,** **34Mb/s 75 $\Omega$ OUT**

PDH / DSn transmitter output interface. Provides 75  $\Omega$  unbalanced DS3, 2 MB/s and 34 Mb/s data output. A “keep alive” signal is output when the transmit signal is SDH/SONET.

## Installation

### Connecting to the Network

***DS1 100 Ω,  
2Mb/s 120 Ω IN***

PDH / DS1 receiver input interface. Allows the connection of 100 Ω balanced DS1 and 120 Ω balanced 2 Mb/s data signals.

***DS1 100 Ω,  
2Mb/s 120 Ω OUT***

PDH / DS1 transmitter output interface. Provides 100 Ω balanced DS1 and 120 Ω balanced 2 Mb/s data signals. A “keep alive” signal is output when the transmit signal is SDH/SONET.

***52/155 Mb/s  
DATA IN***

SDH/SONET receiver input interface. Allows the connection of 75 Ω unbalanced STM 0/1, STS 1/3 electrical signals.

***52/155 Mb/s  
DATA OUT***

SDH/SONET transmitter output interface. Provides a 75 Ω unbalanced STM 0/1, STS 1/3 electrical output.

***64k REF IN  
1.5M REF IN  
2M REF IN  
REF OUT***

These ports allow connection of timing reference signals.

Provides a 2 MHz reference Clock Output.

***MUX***

Allows the insertion of an external 2 Mb/s tributary into the transmitted payload.

***MUX DS1 100 Ω***

Allows an externally supplied DS1 signal to be inserted in any or all timeslot(s) of a DS3 signal. In conjunction with the SDH/SONET module a DS1 signal can be inserted into a VT1.5 or TU-11.

***MUX 2 Mb/s 75 Ω***

Allows an externally supplied 2.048 Mb/s signal to be inserted in any or all timeslot(s) of a 34 Mb/s signal. In conjunction with the SDH module a 2.048 Mb/s signal can be inserted into a TU-12.

***DEMUX DS1  
100 Ω***

Allows a DS1 signal to be dropped from any timeslot of a DS3 signal. In conjunction with the SDH/SONET module this port allows the demultiplexing of a DS1 signal carried in a VT1.5

***DEMUX  
2 Mb/s 75 Ω***

Allows a 2.048 Mb/s signal to be dropped from any timeslot of an 8.448 Mb/s, 34.368 Mb/s or 139.264 Mb/s signal.

Installation

**Connecting to the Network**

**CLOCK TRIGGER** Reference SDH/SONET clock trigger output 51 MHz; nominal +/- 400 mV into 50 ohms.

**DCC** Allows the Drop and Insert of Regenerator Section (192 kb/s) and Multiplexer Section (576 kb/s) Data Communication Channels (DCC).

The following connections are available:

---

**Table 1** **DCC Connector Pin-out**

Pin Number	Connection
1	Shield Ground
2	Data input for Tx(-)
3	Tx Clock
4	Data Output from Rx(-)
5	NC
6	Rx Clock(-)
7	NC
8	Signal Ground
9	Data Input for Tx(+)
10	Tx Clock(+)
11	Data output from Rx(+)
12	NC
13	Rx Clock(+)
14	NC
15	NC

**PROTECTED  
MONITOR POINT  
INPUT** 52/155/622 Mb/s (NRZ); Line Code NRZ; Level nominal 1 V p-p into 50 ohms;  
SMA connector.



## Optical Interface Connectors

For your protection, review all laser information given in this manual before installing or using the instrument.

---

**WARNING**

---

**To prevent personal injury, avoid use that may be hazardous to others, and maintain the module in a safe condition. Ensure the information given below is reviewed before operating the module.**

### Laser Product Classification

All optical modules are classified as Class I (non-hazardous) laser product in the USA which complies with the United States Food and Drug Administration (FDA) Standard 21 CFR Ch.1 1040.10, and are classified as Class 1 (non-hazardous) laser products in Europe which complies with EN 60825-1 (1994).

To avoid hazardous exposure to laser radiation, it is recommended that the following practices are observed during system operation:

- **ALWAYS DEACTIVATE THE LASER BEFORE CONNECTING OR DISCONNECTING OPTICAL CABLES.**
- When connecting or disconnecting optical cables between the module and device-under-test, observe the connection sequences given below.

**Connecting:** Connect the optical cable to the input of the device-under-test **before** connecting to the module's *Optical Out* connector.

**Disconnecting:** Disconnect the optical cable from the module's *Optical Out* connector **before** disconnecting from the device-under-test. Always fit the fibre optic connector dust caps over the laser aperture.

- NEVER examine or stare into the open end of a broken, severed, or disconnected optical cable when it is connected to the module's *Optical Out* connector.
- Arrange for service-trained personnel, who are aware of the hazards involved, to repair optical cables.

## Connecting to the Network

---

### CAUTION

1. Use of controls or adjustments or performance of procedures other than those specified herein may result in hazardous radiation exposure.
  2. Always fit the fibre optic connector dust caps on each connector when not in use. Before connection is made, *always* clean the connector ferrule tip with acetone or alcohol and a cotton swab. Dry the connector with compressed air. Failure to maintain cleanliness of connectors is liable to cause excessive insertion loss.
- 

### Laser Warning Symbols

The front panel of the optical module has the following label:

#### **CLASS 1 LASER PRODUCT**

---

### NOTE

CLASS 1 LASER PRODUCT translates as follows:

Finnish - LUOKAN 1 LASERLAITE

Finnish/Swedish - KLASS 1 LASER APPARAT

---

This label indicates that the radiant energy present in this instrument is non-hazardous.

### **OPTICAL IN**

Allows connection of an optical signal, wavelength 1200 to 1600 nm, at a maximum power level of -8 dBm. **NEVER EXCEED +3 dBm.**

Accepts STM-0, STM-1, STM-4 and STM-16. Also accepts SONET signals, STS-1, STS-3, STS-12, STS-48, OC-1, OC-3, OC-12 and OC-48.

### **OPTICAL OUT**

Provides an STM-0, STM-1, STM-4 or STM-16 optical signal (OC-1, OC-3, OC-12 or OC-48 SONET signals) at wavelength 1280 to 1330nm, and/or 1550 to 1565 nm, at a nominal power level of +1 dBm.

### **Cleaning Optical Connectors**

See "Optical Connector Cleaning" on page 1-8

## **Connecting Accessories**

<b>LID</b>	Provides the output for the option 602 printer which is fitted in the cover (LID) of the instrument.
<b>VGA</b>	Provides the output for a display monitor.
<b>HANDSET</b>	Allows connection of a telephone handset for communication across the network.
<b>Printer</b> <b>HP-IB, RS232,</b> <b>PARALLEL ONLY</b>	External printer connection details are given in the Users Guide. The port selected for external printer use is not available for remote control.
<b>Remote Control</b> <b>HP-IB, RS232,</b> <b>10 BASE -T</b>	Remote control connection is given in the Remote Control Manual. The port selected for remote control use is not available for an external printer.

### **10 Base-T Lan Connection Radiated Emissions**

To ensure compliance with EN 55011 (1991) a category 5, FTP patch lead, RJ45 cable should be used to connect the LAN port on the processor module marked "10 Base-T".

Installation  
**Connecting Accessories**

## **Hewlett-Packard Interface Bus**

The HP 37718A/19A Communications Performance Analyzer (Option 601) is connected to the HP-IB by means of an appropriate HP-IB cable. The HP-IB interconnecting cables available are listed in the following table.

### **HP-IB Interconnecting Cables**

Length	Accessory Number
1 meter	HP 10833A
2 meters	HP 10833B
4 meters	HP 10833C
0.5 meter	HP 10833D

To achieve interface design performance standards, restrictions are placed on the HP-IB system cable lengths. These restrictions allow the bus interface electronics to maintain correct line voltage levels and timing relationships.

When connecting an HP-IB system the following rules should be observed:

The total HP-IB cable length used must be less than or equal to 20 meters (65.6 feet).

The total HP-IB cable length used must be less than or equal to 2 meters (6 feet) × the total number of devices connected to the bus.

A standard HP-IB connector is provided on the instrument. The connections are shown in the following figure. The mating connector part number is HP 1251-0293 or Amphenol 57-30240.

Installation  
**Connecting Accessories**

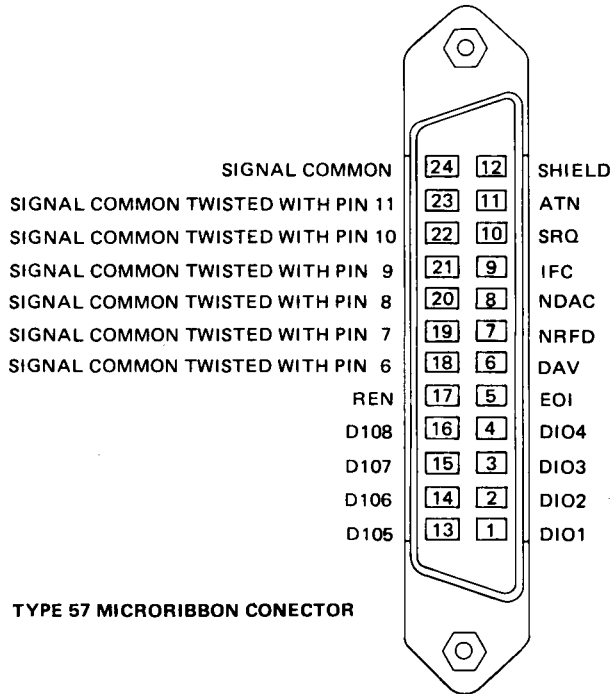

**HP-IB Connections**

**HP-IB Address Selection**

The HP 37718A/19A (Option 601) HP-IB address is accessed on the OTHER display under the REMOTE CONTROL function.

The address can be set to any value between 0 and 30 inclusive.

## **Additional Precautions for Service Engineers**

### **Safety Precautions**

**DO NOT** substitute parts or modify equipment: Because of the danger of introducing additional hazards, do not install substitute parts or perform any unauthorized modification to the product. Return the product to a Hewlett-Packard Sales and Service Office for service and repair to ensure the safety features are maintained.

**DO NOT** service or adjust alone: Under certain conditions, dangerous voltages may exist even with the equipment switched off. To avoid dangerous electrical shock, service personnel must not attempt internal service or adjustment unless another person, capable of rendering first aid and resuscitation, is present.

Review “Safety Precautions for the Operator” on page 1-6

### **ESD Precautions**

---

#### **CAUTION**

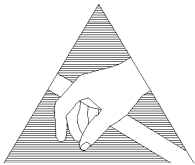

When making connections to the modules, review “Connecting to the Network” on page 2-6

The module contains components sensitive to electrostatic discharge. To prevent component damage, carefully follow the handling precautions presented below.

The smallest static voltage most people can feel is about 3500 volts. It takes less than one tenth of that (about 300 volts) to destroy or severely damage static sensitive circuits. Often, static damage does not immediately cause a malfunction but significantly reduces the component's life. Adhering to the following precautions will reduce the risk of static discharge damage.

- Keep the module in its conductive storage box when not installed in the Mainframe. Save the box for future storage of the module.
- Before handling the module, select a work area where potential static sources are minimized. Avoid working in carpeted areas and non-conductive chairs. Keep body movement to a minimum. Hewlett-Packard

## Installation

### Additional Precautions for Service Engineers

- recommends that you use a controlled static workstation.
- Handle the module by its front-panel. Avoid touching any components or edge connectors. When you install the module, keep one hand in contact with the protective bag as you pick up the module with your other hand. Then, before installing the module, ensure that you are grounded or make contact with the metal surface of the Mainframe with your free hand to bring you, the module, and the mainframe to the same static potential. **This also applies whenever you connect/disconnect cables on the front-panel.**

## **Front Panel Soft Recovery (Cold Start)**

Use the following procedure if you need to perform a front panel soft recovery (i.e. cold start) of the instrument.

### **Soft Recovery Procedure**

- 1** Switch off the instrument.
- 2** On the instrument front panel - press and hold softkeys 0 and 4 simultaneously (the softkeys immediately below the display; key 0 is on the extreme left).
- 3** Power up the HP 37718A or HP 37719A while holding the softkeys pressed.
- 4** When the LOS LED has flashed OFF and then ON again, the keys can be released.
- 5** The LOS LED will flash OFF/ON again several times (7), followed by an audible 'beep' and the display indicating 'Initializing Instrument'.
- 6** Once the initiations is complete the display will indicate:  
'Firmware Revision Update'  
'Default settings assumed'  
Hit any key to attempt restart'
- 7** Hit any key, then wait approximately 10 seconds. The instrument should return to its default settings and normal operation.



# 3 Performance Tests

## **Introduction**

The procedures given in this Section, test the HP 37718A/19A performance using the Specifications provided, as performance standards. Tests are intended to be performed in the recommended order for a full instrument calibration check. Tests can be run individually, however it will be assumed that any preceding test would meet specifications.

## **Equipment Required**

Equipment required for the Performance Tests is given in this Chapter. Any equipment which meets or exceeds the critical specification of the equipment listed, may be substituted. Recommended models are those typically used in HP Service Centers. Alternative models are also listed.

## **Performance Test Record**

The results of the Performance Tests may be recorded on the Test Records at the end of this Chapter. The Performance Test Record lists all the tested specifications and the acceptable limits. The results recorded at incoming inspection may be used for comparison during periodic maintenance, troubleshooting or after repair or adjustment.

## **Calibration Cycle**

This instrument requires periodic verification of performance. Depending on use and environmental conditions, the instrument should be checked approximately once every 2 years, using these Performance Tests.

## **Option Configuration**

Please refer to Chapter 6 and the instrument Specifications for information on option configuration.

## Performance Tests

**Table 3-1 Recommended Test Equipment**

<b>Instrument</b>	<b>Critical Specification</b>	<b>Recommended Model</b>
Oscilloscope	400 MHz Bandwidth, 1 M $\Omega$ Input Termination Telecom mask measurement capability.	HP 54520A opt 001 or HP 54810A opt 001
Frequency Synthesizer	75 $\Omega$ Output, Sinewave to 80 MHz, Amplitude to 3 V pk-pk at 10 kHz, 1 Hz resolution	HP 3335A opt 001 or HP 3325B & HP 8657A with 50/75 $\Omega$ matching pad
Signal Generator	Sinewave 700 kHz to 170 MHz, Amplitude 500 mV	HP 8657A
Frequency Counter	Range 0 to 200 MHz, 2 channels with accuracy <0.1ppm. (Ratio Mode)	HP 5325A opt 010 or HP 53181A opt 001
Spectrum Analyzer**	Frequency >2.5 Gb/s. Resolution bandwidth 10 Hz.	HP 8560E
Optical Coupler**	1310 and 1510 nm. 10/90% output.	HP 15477C
Optical Power Meter and Sensor Module	Range -8 dBm to -15 dBm, Wavelength 1270-1560 nm	HP 8153A and HP 81536A
Lightwave Converter	Wavelength 1300 to 1560 nm, Conversion Gain >300 volts/watt, Frequency Response < 3 dB down at 1 GHz.	HP 11982A opt 012
Optical Attenuator	Wavelength 1200 - 1600 nm, Range 0 - 30 dB	HP 8157A or HP 8156A opt 100
FC/PC Optical Interface Connector	Unique	HP 81000FI (Qty 4)
Optical Cables	Unique	HP 11871A (Qty 2)
PDH Structured Test Set	Unique	HP 37718A/37719A or HP 37717C opt UKJ
64 kb/s Clock Generator	64 kb/s ternary clock.	HP 37732A
75 $\Omega$ Attenuator Kit	0 to 200 MHz 3, 6, 10, 20 dB fixed attenuator pads	HP 86213A
Cable Simulator #E1	75 $\Omega$ coaxial cable 6dB loss at 1 MHz	8120-0049 (120 m)*
Cable Simulator #E2	75 $\Omega$ coaxial cable 6dB loss at 4 MHz	8120-0049 (80 m)*
Cable Simulator #E3	75 $\Omega$ coaxial cable 12dB loss at 17 MHz	8120-0049 (120 m)*
Cable Simulator #E4	75 $\Omega$ coaxial cable 12dB loss at 70 MHz	8120-0049 (80 m)*

## Performance Tests

**Table 3-1 Recommended Test Equipment, continued**

<b>Instrument</b>	<b>Critical Specification</b>	<b>Recommended Model</b>
Cable Simulator #E1-M	75Ω coaxial cable 3dB loss at 1 MHz	8120-0049 (60 m)*
Cable Simulator #E2-M	75Ω coaxial cable 3dB loss at 4 MHz	8120-0049 (40 m)*
Cable Simulator #E3-M	75Ω coaxial cable 6dB loss at 17 MHz	8120-0049 (60 m)*
Cable Simulator #E4-M	75Ω coaxial cable 6dB loss at 70 MHz	8120-0049 (40 m)*
Cable Simulator #DS1	75Ω coaxial cable. Equivalent to 655 feet ABAM cable.	8120-0049 (80m)*
Cable Simulator #DS3	75Ω coaxial cable. Equivalent to 450 feet of 728A cable	8120-0049 (55m)*
Cable Simulator STM-0/ STS-1	75Ω coaxial cable 6dB loss at 26 MHz	8120-0049 (50 m)*
Cable Simulator STM-1/ STS-3	75Ω coaxial cable 12dB loss at 78 MHz	8120-0049 (75 m)*
75Ω Termination	0 to 200 MHz	HP 15522-80010
T Connector	BNC to Dual BNC	HP 1250-0781
Adaptor	SMA to BNC	1250-1787 (Qty 2)
Adaptor	Type N to BNC	HP 1250-1534 (Qty 2)
Adaptor	Type N to N	HP 1250-1528 (Qty 2)
Balanced/Unbalanced Converter	110Ω balanced: 75Ω Unbalanced (nominal)	HP 15508B (Qty 2)
Blocking Capacitor	0.18uF 200V	HP 10240B

\* Note: Cable lengths quoted are typical for the half bit rate loss. Ideally, cables should be trimmed to correct length/loss by measuring with a Network Analyzer.

\*\* Note: Spectrum Analyzer/Optical Coupler are only required for 37718A Jitter options.

### **Self Test Loopback Cables and Accessories**

HP E4545A 3m fibre optic cable FC/CP connectors. (supplied accessory)

HP E4546A FC/CP 15 dB attenuator. (supplied accessory)

HP 15525A 75 ohm BNC, 3 off.

HP 15512A Siemens 3 pin (Option 010 units)

HP 15670A Bantam 110 ohm (Option 011 units), 2 off.

DCC 15 pin loopback plug - see figure in DCC Test.

Formatted floppy disk.

## Recall Default Settings

The Performance Tests require the HP 37718A/19A to be set to a pre-defined (default) state at the beginning of each test.

- 1 Using **OTHER**, display softkeys, **↓** **↑** **→** and **←** set up the **OTHER** **STORED** **SETTINGS** display as shown opposite

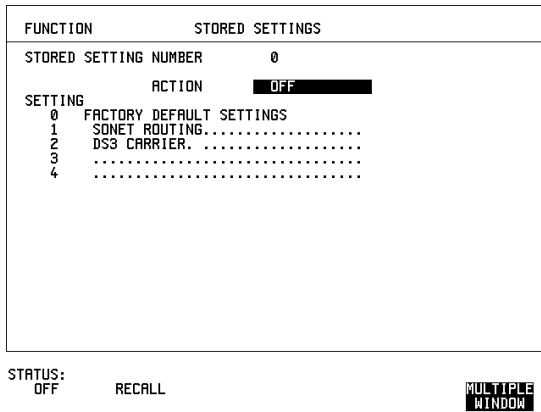

- 2 Press **RECALL** to recall the instrument default settings. The instrument display will blank for a few seconds while the settings are recalled and the status display will indicate stored settings number 0 recalled.

---

## Self Test

### Description

Before carrying out the performance tests run Self Test to ascertain the integrity of the HP 37718A/19A. These tests take at least 1 hour to complete depending on the options fitted. Alternatively you can run Confidence Tests which only takes 2 to 3 minutes to complete. This is not a full verification but performs BER measurements with internal and external loopbacks fitted.

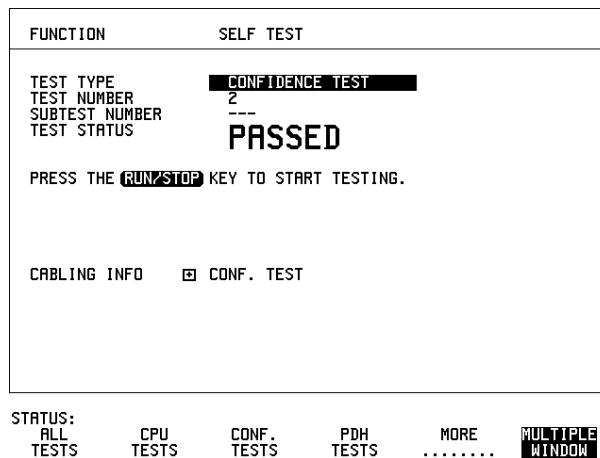

### Run Confidence TESTS

- 1 Choose TEST TYPE **CONF. TESTS** on the **OTHER** **SELF TEST** display.

---

#### CAUTION

Safety precaution, care and connection cleanliness are essential to avoid optical signal degradation or damage. see Operators Maintenance in chapter 1 and see Optical Interface Connectors in chapter 2 if in doubt. The use of air-gap attenuators is not recommended. Failure to attenuate the optical signal could result in damage to the optical receiver.

---

## Performance Tests

### Self Test

---

#### NOTE

If the Optical Interface is a Dual Wavelength Option the **1550 nm** IN and OUT ports are not connected at this stage and can be tested later. If any or all of these connections are not made the HP 37718A/19A will FAIL Self Test.

---

- 2** Make the loopback connections listed below:  
Connect the 15 dB optical attenuator provided at the Optical OUT and then connect the attenuator output to Optical IN using the optical cable supplied with your instrument.  
Connect Multirate Analyser IN to OUT  
Connect Transmit module 75 $\Omega$  OUT to Receive module 75 $\Omega$  IN  
Connect Transmit module 100/120 $\Omega$  OUT to Receive module 100/120 $\Omega$  IN
- 3** Press **RUN/STOP** to activate the Self Test. TEST STATUS RUNNING will be displayed.  
The information pertaining to TEST TYPE, TEST NUMBER and SUBTEST NUMBER will change as the Self Test progresses.  
If the HP 37718A/19A is functioning correctly, after a time of 2 to 3 minutes, TEST STATUS PASSED is displayed.  
If TEST STATUS [FAIL nnn] is displayed, check the displayed error information and check loopback connections are correct. Repeat the test and if the problem persists contact your local HP representative. See Chapter 5 for information.

---

#### NOTE

Each individual self test requires unique loopback connections. To obtain a list of the connections required move the highlighted cursor to CABLING INFO and press **SET**. The Loopbacks list will appear on the display. Also refer to Chapter 5 for Self Test connection information.

---

## Performance Tests

### Self Test

FUNCTION	SELF TEST
TEST TYPE	PDH TESTS
TEST NUMBER	3
SUBTEST NUMBER	---
TEST STATUS	<b>RFADV</b>

PDH SELFTEST - CABLING INFORMATION

PAYLOAD MODULE CONNECTIONS :

- CONNECT PDH OUT TO PDH IN (UNBALANCED DS3, 210k/s, 341k/s)
- CONNECT PDH OUT TO PDH IN (BALANCED 210k/s)
- CONNECT MUX TO DEMUX (BALANCED DS1)
- CONNECT MUX TO DEMUX (UNBALANCED 210k/s)

STATUS:

**MULTIPLE  
WINDOW**

### Run ALL TESTS

- 1 Choose TEST TYPE **ALL TESTS** on the **OTHER SELF TEST** display.
- 2 Insert a formatted disk into the instrument disk drive.
- 3 Make the loopback connections listed below:  
Connect the 15 dB optical attenuator provided to Optical OUT and connect the attenuator output to Optical IN.  
Connect Multirate Analyser IN to OUT  
Connect Transmit module 75Ω OUT to Receive module 75Ω IN  
Connect Transmit module 100/120Ω OUT to Receive module 100/120Ω IN  
Connect Transmit module 75Ω MUX to Receive module 75Ω DEMUX  
Connect Transmit module 100/120Ω MUX to Receive module 100/120Ω DEMUX
- 4 Press **RUN/STOP** to activate the Self Test. TEST STATUS RUNNING will be displayed.  
The information pertaining to TEST TYPE, TEST NUMBER and SUBTEST NUMBER will change as the Self Test progresses.  
If the HP 37718A/19A is functioning correctly, after a time of at least 1 hour, TEST STATUS PASSED is displayed.  
If TEST STATUS [FAIL nnn] is displayed, check the displayed error information and check loopback connections are correct. Repeat the test and if the problem persists contact your local HP representative. See Chapter 5 for information.

## Performance Tests

### Self Test

FUNCTION	SELF TEST
TEST TYPE	ALL TESTS
TEST NUMBER	0
SUBTEST NUMBER	---
TEST STATUS	READY
PRESS THE <b>RUN/STOP</b> KEY TO START TESTING.	
CABLING INFO	<input type="checkbox"/> ALL

STATUS:  
ALL TESTS    CPU TESTS    CONF. TESTS    PDH TESTS    MORE .....    **MULTIPLE WINDOW**

#### **1550 nm Dual Wavelength Tests:**

If a Dual Wavelength Optical Interface is fitted, repeat the CONFIDENCE test with 1550 nm selected.

- 1 Select 1550 nm OPTICS wavelength
- 2 Connect 1550 nm OUT to IN via 15dB Optical Attenuator. Ensure the attenuator is inserted in the OUT port.
- 3 Run the test.



## Performance Tests

### Self Test

#### **DCC Port Tests:**

- 1 Select BER TESTS
- 2 Make the following connections at the Multirate Analyzer DCC port.

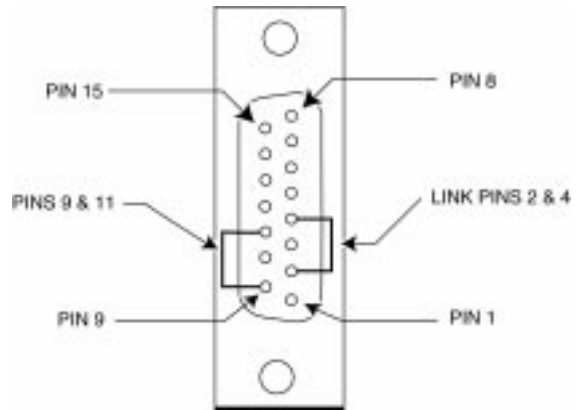

- 3 Run the BER TESTS.

---

## PDH/DSn Internal Transmitter Clock Accuracy & Offset

### Specifications

Rate	Frequency
E4	139.264 MHz $\pm$ 4.5 ppm
E3	34.368 MHz $\pm$ 4.5 ppm
E2	8.448 MHz $\pm$ 4.5 ppm
E1	2.048 MHz $\pm$ 4.5 ppm
DS1	1.544 MHz $\pm$ 4.5 ppm
DS3	44.736 MHz $\pm$ 4.5 ppm

---

#### NOTE

The Rates available are dependent on the HP 37718A/19A option.

#### Description

This test verifies that the PDH transmit data rates are within limits. These limits assume the instrument is within the calibration cycle. The Frequency Offset capability (deviation from Standard Bit Rate) is also checked.

For E1 to E4 a Frequency Counter connected to the PDH/DSn Signal Out port measures the data rate on an "all ones" pattern. This gives an indirect measure of the internal transmitter clock frequency as the data is clocked by the internal clock oscillator. Because the Frequency Counter triggers from the positive pulses only, the frequency count will, for Ternary signals E1, E2 & E3, be half the selected data rate.

For DS-1 and DS-3 the Frequency Counter is connected to the CLOCK OUT port.

#### Equipment Required

<b>Frequency Counter</b>	: HP 5335A Option 010
<b>75<math>\Omega</math> Termination</b>	: HP 15522-80010
<b>T Connector</b>	: HP 1250-0781

**PDH/DSn Internal Transmitter Clock Accuracy & Offset**

**Procedure**

- 1 Recall the HP 37718A/19A DEFAULT SETTINGS as shown on Page 3-4.
- 2 Connect the 75Ω OUT port of the PDH/DSn module to the Frequency Counter. Terminate the Frequency Counter input in 75Ω (use the T connector).
- 3 Set the **TRANSMIT** display as shown opposite

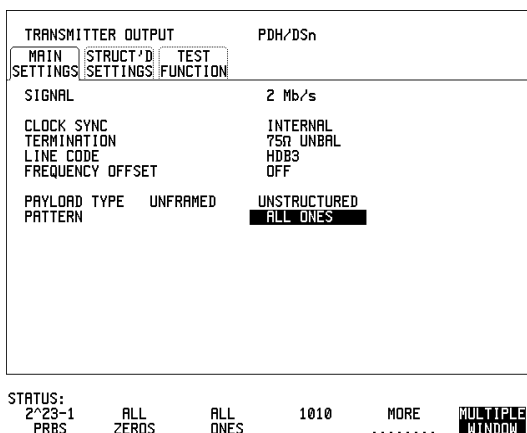

**NOTE**

When changing the PDH Rate or Offset value the VCXO takes time to settle. As a consequence the frequency counter reading will not stabilize until "VCXO OUTPUT BIT RATE SETTLING" clears from the STATUS line of the display.

**E1 (2.048Mb/s) Frequency Accuracy**

- 4 Adjust the Frequency Counter ATTEN and Trigger Level to obtain a stable reading and ensure that the frequency counter reading is between 1023995Hz and 1024005Hz.
- 5 Select FREQUENCY OFFSET [+50PPM].
- 6 Adjust the Frequency Counter ATTEN and Trigger Level to obtain a stable reading and ensure that the frequency counter reading is between 1024046.5Hz and 1024055.5Hz.

## PDH/DSn Internal Transmitter Clock Accuracy & Offset

- 7 Select FREQUENCY OFFSET [-50PPM].
- 8 Adjust the Frequency Counter ATTEN and Trigger Level to obtain a stable reading and ensure that the frequency counter reading is between 1023944Hz and 1023953Hz.

### **E2 (8.448Mb/s) Frequency Accuracy**

- 9 Select SIGNAL [8Mb/s]; PATTERN [ALL 1's] on the **TRANSMIT** display.
- 10 Adjust the Frequency Counter ATTEN and Trigger Level to obtain a stable reading and ensure that the frequency counter reading is between 4223981Hz and 4224019Hz.
- 11 Select FREQUENCY OFFSET [+30PPM].
- 12 Adjust the Frequency Counter ATTEN and Trigger Level to obtain a stable reading and ensure that the frequency counter reading is between 4224107.5Hz and 4224145.7 Hz.
- 13 Select FREQUENCY OFFSET [-30PPM].
- 14 Adjust the Frequency Counter ATTEN and Trigger Level to obtain a stable reading and ensure that the frequency counter reading is between 4223854Hz and 4223892Hz.

### **E3 (34.368Mb/s) Frequency Accuracy**

- 15 Select SIGNAL [34Mb/s] PATTERN [ALL 1's] on the **TRANSMIT** display.
- 16 Adjust the Frequency Counter ATTEN and Trigger Level to obtain a stable reading and ensure that the frequency counter reading is between 17183922.7Hz and 17184077.4Hz.
- 17 Select FREQUENCY OFFSET [+20PPM]
- 18 Adjust the Frequency Counter ATTEN and Trigger Level to obtain a stable reading and ensure that the frequency counter reading is between 17184266 and 17184421Hz.
- 19 Select FREQUENCY OFFSET [-20PPM]
- 20 Adjust the Frequency Counter ATTEN and Trigger Level to obtain a stable reading and ensure that the frequency counter reading is between 17183579Hz and 17183734Hz.

### **PDH/DSn Internal Transmitter Clock Accuracy & Offset**

- 21 Select FREQUENCY OFFSET [USER OFFSET] [+100PPM]
- 22 Adjust the Frequency Counter ATTEN and Trigger Level to obtain a stable reading and ensure that the frequency counter reading is between 17185641Hz and 17185796Hz.
- 23 Select FREQUENCY OFFSET [USER OFFSET] [-100PPM]
- 24 Adjust the Frequency Counter ATTEN and Trigger Level to obtain a stable reading and ensure that the frequency counter reading is between 17182205Hz and 17182359Hz.

### **E4 (139.264Mb/s) Frequency Accuracy**

- 25 Select SIGNAL [140Mb/s] PATTERN [ALL 1's] on the **TRANSMIT** display.
- 26 Adjust the Frequency Counter ATTEN and Trigger Level to obtain a stable reading and ensure that the frequency counter reading is between 69631686.5Hz and 69632318.5Hz.
- 27 Select FREQUENCY OFFSET [+15PPM].
- 28 Adjust the Frequency Counter ATTEN and Trigger Level to obtain a stable reading and ensure that the frequency counter reading is between 69632731Hz and 69633358Hz.
- 29 Select FREQUENCY OFFSET [-15PPM].
- 30 Adjust the Frequency Counter ATTEN and Trigger Level to obtain a stable reading and ensure that the frequency counter reading is between 69630642Hz and 69631269Hz.

### **DS1 (1.544Mb/s) Frequency Accuracy**

- 31 Connect the CLOCK OUT port of the PDH/DSn module to the Frequency Counter.
- 32 Select SIGNAL [DS1 1.5Mb/s] on the **TRANSMIT** display.
- 33 Adjust the Frequency Counter ATTEN and Trigger Level to obtain a stable reading and ensure that the frequency counter reading is between 1543993Hz and 1544007Hz.
- 34 Select FREQUENCY OFFSET [+32PPM]
- 35 Adjust the Frequency Counter ATTEN and Trigger Level to obtain a stable reading and ensure that the frequency counter reading is

**PDH/DSn Internal Transmitter Clock Accuracy & Offset**

between 1544042Hz and 1544056Hz.

**36** Select FREQUENCY OFFSET [-32PPM]

**37** Adjust the Frequency Counter ATTEN and Trigger Level to obtain a stable reading and ensure that the frequency counter reading is between 1543944Hz and 1543958Hz.

**DS3 (44.736Mb/s) Frequency Accuracy**

**38** Connect the CLOCK OUT port of the PDH/DSn module to the Frequency Counter.

**39** Select SIGNAL [DS3] on the **TRANSMIT** display.

**40** Adjust the Frequency Counter ATTEN and Trigger Level to obtain a stable reading and ensure that the frequency counter reading is between 44735799Hz and 44736201Hz

**41** Select FREQUENCY OFFSET [+20PPM]

**42** Adjust the Frequency Counter ATTEN and Trigger Level to obtain a stable reading and ensure that the frequency counter reading is between 44736693Hz and 44737096Hz.

**43** Select FREQUENCY OFFSET [-20PPM]

**44** Adjust the Frequency Counter ATTEN and Trigger Level to obtain a stable reading and ensure that the frequency counter reading is between 44734904Hz and 44735307Hz.

**45** Disconnect all the test equipment.

## **PDH/DSn Transmitter Output**

### **Specification**

<b>Rate</b>	<b>Level</b>	<b>Waveshape</b>
DSX-1	3.0V 20%	Fits mask T1.102-1993
DS1-LO	As DSX-1 with 655' ABAM Cable	
DS3-HI	0.9V pk (nominal)	
DSX-3	560mV pk (nominal)	Fits mask T1.102-1993
DS3-900	330mV pk (nominal)	
E1 Balanced	3.00V 10%	As per ITU rec G703
E1 Unbalanced	2.37V 10%	As per ITU rec G703
E2 Unbalanced	2.37V 10%	As per ITU rec G703
E3 Unbalanced	1.0V 10%	As per ITU rec G703
E4 Unbalanced	0.5V 10%	As per ITU rec G703

---

#### **NOTE**

The Rates available are dependent on the HP 37718A/19A option

#### **Description**

This test ensures the transmitter output level and pulse shape meet the required specifications at all PDH/DSn rates. The Transmitter output is connected to an Oscilloscope and the waveshape compared with the predefined masks stored in the Oscilloscope memory. The signal levels are also measured using the Oscilloscope.

Performance Tests  
**PDH/DSn Transmitter Output**

## Equipment Required

Oscilloscope	: HP 54520A Option 001
110Ω/75Ω Balanced to Unbalanced Converter	: HP 15508B
75Ω Termination	: HP 15522-80010

## Procedure

---

### NOTE

This performance test is written using the HP 54520A Oscilloscope with Option 001 - Telecom Masks Application. If any other Oscilloscope is used the keystrokes given in this procedure will not apply. The Positive pulse masks are contained in the ROOT directory of the Telecom Mask Application Disk and the Negative pulse masks are in the INV\_MASK directory.

---

## Installing the Telecom Masks Option

- 1 Insert the Disk containing the Telecom Mask into the Oscilloscope Disk Drive.
- 2 Press SHIFT (Blue Key) DISK
- 3 Press **DIRECTORY** softkey then **ROOT DIRECTORY** softkey

### 139.264 Mb/s - All 1's Pulse

- 1 Recall the HP 37718A Default Settings as shown on page 3-4.
- 2 Set the **TRANSMIT** display as shown below.

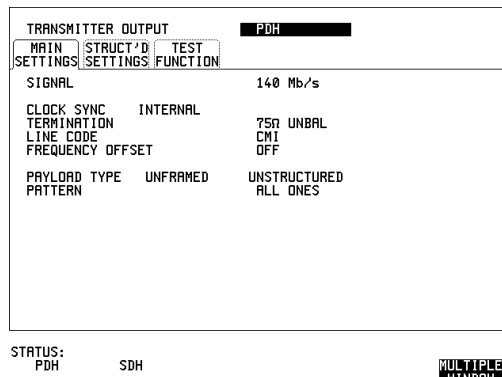



### PDH/DSn Transmitter Output

- 3 Connect the PDH/DSn 75Ω OUT port to the Oscilloscope CHAN 1, terminate in 75Ω
- 4 Select CHAN 1 on the Oscilloscope and set to 1MΩ input impedance.

#### Load the Telecom Mask

- 5 On the Oscilloscope, use the following key sequence to select and load the required Telecom Mask:
  - a/ SHIFT (Blue Key) APPLICATION.
  - b/ **TELECOM MASK/MASK** softkey.
  - c/ Use ENTRY/MEASURE control to select 139BIN1 in the highlighted MSK FILES window.
  - d/ **LOAD SETUP 8 M1M2** softkey.

#### Compare Pulse with Mask

- 6 On the Oscilloscope, use the following key sequence to compare the pulse with the mask:
  - a/ RECALL 8
  - b/ DEFINE MEAS
  - c/ **COMPARE** softkey
  - d/ **TEST ON** softkey
  - e/ **M1M2** softkey
  - f/ **AFTER FAIL CONTINUE** softkey
  - g/ RUN
- 7 The Oscilloscope will automatically display and compare an isolated positive pulse with the mask limits. A PASS message should appear on the Oscilloscope.

---

#### NOTE

---

It may be necessary to visibly fit the waveform to the mask by adjusting the Oscilloscope vertical position and horizontal delay to obtain a PASS on the Mask.

- 8 Measure the peak pulse amplitude at the mid pulse-width using the Oscilloscope and verify that this is between 450 mV and 550 mV. (i.e. 900 mV-1.1V Pk-Pk)

#### All 0's Pulse

- 9 Select PATTERN [ALL 0's] on the **TRANSMIT** display.

Performance Tests  
**PDH/DSn Transmitter Output**

**Load the Telecom Mask**

- 10** On the Oscilloscope, use the following key sequence to select and load the required Telecom Mask:
- a/ SHIFT (Blue Key) APPLICATION.
  - b/ **TELECOM MASK/MASK** softkey.
  - c/ Use ENTRY/MEASURE control to select 139BIN0 in the highlighted MSK FILES window.
  - d/ **LOAD SETUP 8 M1M2** softkey.

**Compare Pulse with Mask**

- 11** On the Oscilloscope, use the following key sequence to compare the pulse with the mask:
- a/ RECALL 8
  - b/ DEFINE MEAS
  - c/ **COMPARE** softkey
  - d/ **TEST ON** softkey
  - e/ **M1M2** softkey
  - f/ **AFTER FAIL CONTINUE** softkey
  - g/ RUN
- 12** The Oscilloscope will automatically display and compare an isolated positive pulse with the mask limits. A PASS message should appear on the Oscilloscope.

---

**NOTE**

---

It may be necessary to visibly fit the waveform to the mask by adjusting the Oscilloscope vertical position and horizontal delay to obtain a PASS on the Mask.

- 13** Measure the peak pulse amplitude at the mid pulse-width using the Oscilloscope and verify that this is between 450 mV and 550 mV. (i.e. 900 mV-1.1V Pk-Pk)
- 14** Select PATTERN to [ALL 0's] on the **TRANSMIT** display.
- 15** On the Oscilloscope, use the following key sequence to access the inverted mask.
- a/ SHIFT (Blue Key) DISK
  - b/ **DIRECTORY** softkey
  - c/ Use ENTRY/MEASURE control to highlight INV\_MASK
  - d/ **CHANGE DIRECTORY** softkey
- 16** Repeat steps 5 to 13 to check pulses against Inverted masks.

Performance Tests  
PDH/DSn Transmitter Output

## Procedure - 34.368 Mb/s

### Positive Pulse

- 1 Recall the HP 37718A/19A Default Settings as shown on page 3-4.
- 2 Set the **TRANSMIT** display as shown opposite.

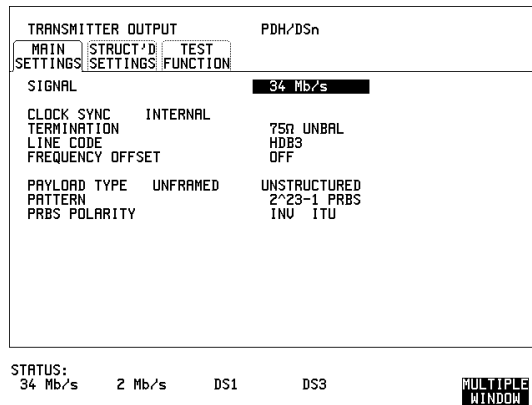

- 3 Connect the PDH/DSn 75Ω OUT port to the Oscilloscope CHAN 1, terminate in 75Ω
- 4 Select CHAN 1 on the Oscilloscope and set to 1MΩ input impedance.

### Load the Telecom Mask

- 5 On the Oscilloscope, use the following key sequence to select and load the required Telecom Mask:
  - a/ SHIFT (Blue Key) APPLICATION.
  - b/ **TELECOM MASK/MASK** softkey.
  - c/ Use ENTRY/MEASURE control to select 34MG703 in the highlighted MSK FILES window.
  - d/ **LOAD SETUP 8 M1M2** softkey.

### Compare Pulse with Mask

- 6 On the Oscilloscope, use the following key sequence to compare the pulse with the mask:
  - a/ RECALL 8

Performance Tests  
**PDH/DSn Transmitter Output**

- b/ DEFINE MEAS
- c/ **COMPARE** softkey
- d/ **TEST ON** softkey
- e/ **M1M2** softkey
- f/ **AFTER FAIL CONTINUE** softkey
- g/ RUN

- 7 The Oscilloscope will automatically display and compare an isolated positive pulse with the mask limits. A PASS message should appear on the Oscilloscope.

---

**NOTE**

---

It may be necessary to visibly fit the waveform to the mask by adjusting the Oscilloscope vertical position and horizontal delay to obtain a PASS on the Mask.

- 8 Measure the peak pulse amplitude at the mid pulse-width using the Oscilloscope and verify that this is between 900 mV and 1.100 Volts.

**Negative Pulse**

- 9 On the Oscilloscope, use the following key sequence to access the inverted mask.
- a/ SHIFT (Blue Key) DISK
  - b/ **DIRECTORY** softkey
  - c/ Use ENTRY/MEASURE control to highlight INV\_MASK
  - d/ **CHANGE DIRECTORY** softkey

**Load the Telecom Mask**

- 10 On the Oscilloscope, use the following key sequence to select and load the required Telecom Mask:
- a/ SHIFT (Blue Key) APPLICATION.
  - b/ **TELECOM MASK/MASK** softkey.
  - c/ Use ENTRY/MEASURE control to select 34MG703 in the highlighted MSK FILES window.
  - d/ **LOAD SETUP 8 M1M2** softkey.

**Compare Pulse with Mask**

- 11 On the Oscilloscope, use the following key sequence to compare the pulse with the mask:
- a/ RECALL 8
  - b/ DEFINE MEAS
  - c/ **COMPARE** softkey

Performance Tests  
**PDH/DSn Transmitter Output**

- d/ **TEST ON** softkey
- e/ **M1M2** softkey
- f/ **AFTER FAIL CONTINUE** softkey
- g/ RUN

12 The Oscilloscope will automatically display and compare an isolated positive pulse with the mask limits. A PASS message should appear on the Oscilloscope

---

**NOTE**

---

It may be necessary to visibly fit the waveform to the mask by adjusting the Oscilloscope vertical position and horizontal delay to obtain a PASS on the Mask.

13 Measure the peak pulse amplitude at the mid pulse-width using the Oscilloscope and verify that this is between 900 mV and 1.100 Volts.

### Procedure - 8.448 Mb/s

#### Positive Pulse

- 1 Recall the HP 37718A/19A Default Settings as shown on page 3-4.
- 2 Set the **TRANSMIT** display as shown opposite.

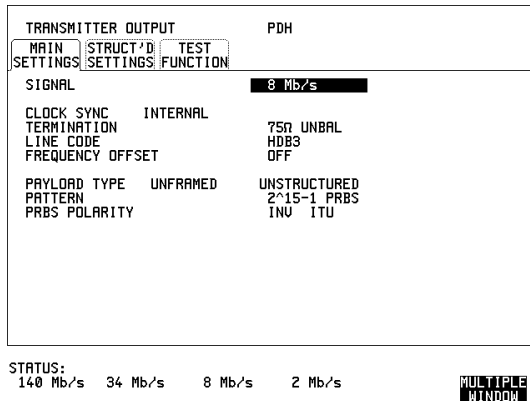

- 3 Connect the PDH/DSn 75Ω OUT port to the Oscilloscope CHAN 1, terminate in 75Ω
- 4 Select CHAN 1 on the Oscilloscope and set to 1MΩ input impedance.

Performance Tests  
**PDH/DSn Transmitter Output**

**Load the Telecom Mask**

- 5 On the Oscilloscope, use the following key sequence to select and load the required Telecom Mask:
  - a/ SHIFT (Blue Key) APPLICATION.
  - b/ **TELECOM MASK/MASK** softkey.
  - c/ Use ENTRY/MEASURE control to select 8MG703 in the highlighted MSK FILES window.
  - d/ **LOAD SETUP 8 M1M2** softkey.

**Compare Pulse with Mask**

- 6 On the Oscilloscope, use the following key sequence to compare the pulse with the mask:
  - a/ RECALL 8
  - b/ DEFINE MEAS
  - c/ **COMPARE** softkey
  - d/ **TEST ON** softkey
  - e/ **M1M2** softkey
  - f/ **AFTER FAIL CONTINUE** softkey
  - g/ RUN
- 7 The Oscilloscope will automatically display and compare an isolated positive pulse with the mask limits. A PASS message should appear on the Oscilloscope.

---

**NOTE**

---

It may be necessary to visibly fit the waveform to the mask by adjusting the Oscilloscope vertical position and horizontal delay to obtain a PASS on the Mask.

- 8 Measure the peak pulse amplitude at the mid pulse-width using the Oscilloscope and verify that this is between 2.133V and 2.607 Volts.

**Negative Pulse**

- 9 On the Oscilloscope, use the following key sequence to access the inverted mask.
  - a/ SHIFT (Blue Key) DISK
  - b/ **DIRECTORY** softkey
  - c/ Use ENTRY/MEASURE control to highlight INV\_MASK
  - d/ **CHANGE DIRECTORY** softkey

Performance Tests  
**PDH/DSn Transmitter Output**

**Load the Telecom Mask**

- 10** On the Oscilloscope, use the following key sequence to select and load the required Telecom Mask:
- a/ SHIFT (Blue Key) APPLICATION.
  - b/ **TELECOM MASK/MASK** softkey.
  - c/ Use ENTRY/MEASURE control to select 8MG703 in the highlighted MSK FILES window.
  - d/ **LOAD SETUP 8 M1M2** softkey.

**Compare Pulse with Mask**

- 11** On the Oscilloscope, use the following key sequence to compare the pulse with the mask:
- a/ RECALL 8
  - b/ DEFINE MEAS
  - c/ **COMPARE** softkey
  - d/ **TEST ON** softkey
  - e/ **M1M2** softkey
  - f/ **AFTER FAIL CONTINUE** softkey
  - g/ RUN
- 12** The Oscilloscope will automatically display and compare an isolated positive pulse with the mask limits. A PASS message should appear on the Oscilloscope

---

**NOTE**

---

It may be necessary to visibly fit the waveform to the mask by adjusting the Oscilloscope vertical position and horizontal delay to obtain a PASS on the Mask.

- 13** Measure the peak pulse amplitude at the mid pulse-width using the Oscilloscope and verify that this is between 2.133V and 2.607 Volts.

**Procedure - 2.048 Mb/s**

**Positive Pulse**

- 1** Recall the HP 37718A/19A Default Settings as shown on page 3-4.

## Performance Tests

### PDH/DSn Transmitter Output

- Set the **TRANSMIT** display as shown below.

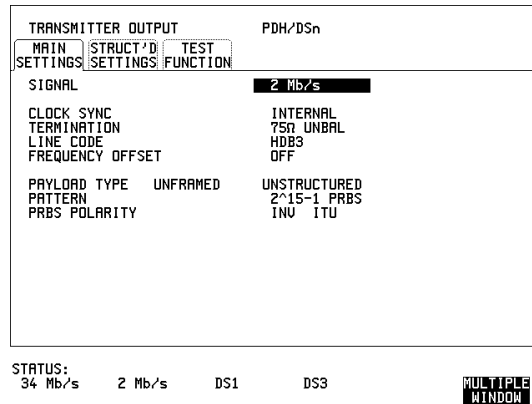

- Connect the PDH/DSn 75Ω OUT port to the Oscilloscope CHAN 1, terminate in 75Ω
- Select CHAN 1 on the Oscilloscope and set to 1MΩ input impedance.

#### Load the Telecom Mask

- On the Oscilloscope, use the following key sequence to select and load the required Telecom Mask:
  - SHIFT (Blue Key) APPLICATION.
  - TELECOM MASK/MASK** softkey.
  - Use ENTRY/MEASURE control to select DS\_1E in the highlighted MSK FILES window.
  - LOAD SETUP 8 M1M2** softkey.

#### Compare Pulse with Mask

- On the Oscilloscope, use the following key sequence to compare the pulse with the mask:
  - RECALL 8
  - DEFINE MEAS
  - COMPARE** softkey
  - TEST ON** softkey
  - M1M2** softkey
  - AFTER FAIL CONTINUE** softkey
  - RUN



## PDH/DSn Transmitter Output

- 7 The Oscilloscope will automatically display and compare an isolated positive pulse with the mask limits. A PASS message should appear on the Oscilloscope.

---

### NOTE

---

It may be necessary to visibly fit the waveform to the mask by adjusting the Oscilloscope vertical position and horizontal delay to obtain a PASS on the Mask.

- 8 Measure the peak pulse amplitude at the mid pulse-width using the Oscilloscope and verify that this is between 2.133V and 2.607 Volts.

### Negative Pulse

- 9 On the Oscilloscope, use the following key sequence to access the inverted mask.
  - a/ SHIFT (Blue Key) DISK
  - b/ **DIRECTORY** softkey
  - c/ Use ENTRY/MEASURE control to highlight INV\_MASK
  - d/ **CHANGE DIRECTORY** softkey

### Load the Telecom Mask

- 10 On the Oscilloscope, use the following key sequence to select and load the required Telecom Mask:
  - a/ SHIFT (Blue Key) APPLICATION.
  - b/ **TELECOM MASK/MASK** softkey.
  - c/ Use ENTRY/MEASURE control to select DS\_1E in the highlighted MSK FILES window.
  - d/ **LOAD SETUP 8 M1M2** softkey.

### Compare Pulse with Mask

- 11 On the Oscilloscope, use the following key sequence to compare the pulse with the mask:
  - a/ RECALL 8
  - b/ DEFINE MEAS
  - c/ **COMPARE** softkey
  - d/ **TEST ON** softkey
  - e/ **M1M2** softkey
  - f/ **AFTER FAIL CONTINUE** softkey
  - g/ RUN
- 12 The Oscilloscope will automatically display and compare an isolated positive pulse with the mask limits. A PASS message should appear on

## Performance Tests

### PDH/DSn Transmitter Output

the Oscilloscope.

---

#### NOTE

---

It may be necessary to visibly fit the waveform to the mask by adjusting the Oscilloscope vertical position and horizontal delay to obtain a PASS on the Mask.

- 13 Measure the peak pulse amplitude at the mid pulse-width using the Oscilloscope and verify that this is between 2.133V and 2.607 Volts.

### Procedure - DSX-3

#### Positive Pulse

- 1 Recall the HP 37718A/19A Default Settings as shown on page 3-4.
- 2 Set the **TRANSMIT** display as shown below.

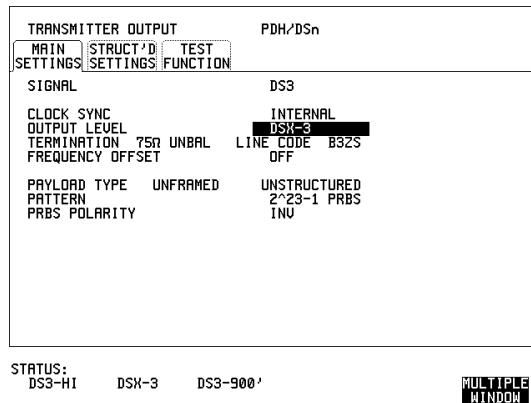

- 3 Connect the PDH/DSn 75Ω OUT port to the Oscilloscope CHAN 1, terminate in 75Ω
- 4 Select CHAN 1 on the Oscilloscope and set to 1MΩ input impedance.

#### Load the Telecom Mask

- 5 On the Oscilloscope, use the following key sequence to select and load the required Telecom Mask:  
a/ SHIFT (Blue Key) APPLICATION.

Performance Tests  
**PDH/DSn Transmitter Output**

- b/ **TELECOM MASK/MASK** softkey.
- c/ Use ENTRY/MEASURE control to select DS3\_92 in the highlighted MSK FILES window.
- d/ **LOAD SETUP 8 M1M2** softkey.

**Compare Pulse with Mask**

- 6 On the Oscilloscope, use the following key sequence to compare the pulse with the mask:
  - a/ RECALL 8
  - b/ DEFINE MEAS
  - c/ **COMPARE** softkey
  - d/ **TEST ON** softkey
  - e/ **M1M2** softkey
  - f/ **AFTER FAIL CONTINUE** softkey
  - g/ RUN
- 7 The Oscilloscope will automatically display and compare an isolated positive pulse with the mask limits. A PASS message should appear on the Oscilloscope.

---

**NOTE**

---

It may be necessary to select **MASK** softkey and **MASK AUTO** / **MASK ALIGN** or visibly fit the waveform to the mask by adjusting the Oscilloscope vertical gain/position and horizontal delay to obtain a PASS on the Mask.

- 8 Measure the peak pulse amplitude at the mid pulse-width using the Oscilloscope and verify that this is nominally 560 mV.

**Negative Pulse**

- 9 On the Oscilloscope, use the following key sequence to access the inverted mask.
  - a/ SHIFT (Blue Key) DISK
  - b/ **DIRECTORY** softkey
  - c/ Use ENTRY/MEASURE control to highlight INV\_MASK
  - d/ **CHANGE DIRECTORY** softkey

**Load the Telecom Mask**

- 10 On the Oscilloscope, use the following key sequence to select and load the required Telecom Mask:
  - a/ SHIFT (Blue Key) APPLICATION.
  - b/ **TELECOM MASK/MASK** softkey.

Performance Tests  
**PDH/DSn Transmitter Output**

- c/ Use ENTRY/MEASURE control to select DS3\_92 in the highlighted MSK FILES window.
- d/ **LOAD SETUP 8 M1M2** softkey.

**Compare Pulse with Mask**

- 11 On the Oscilloscope, use the following key sequence to compare the pulse with the mask:
  - a/ RECALL 8
  - b/ DEFINE MEAS
  - c/ **COMPARE** softkey
  - d/ **TEST ON** softkey
  - e/ **M1M2** softkey
  - f/ **AFTER FAIL CONTINUE** softkey
  - g/ RUN
- 12 The Oscilloscope will automatically display and compare an isolated positive pulse with the mask limits. A PASS message should appear on the Oscilloscope.

---

**NOTE**

---

It may be necessary to select **MASK** and **MASK AUTO / MASK ALIGN** to visibly fit the waveform to the mask by adjusting the Oscilloscope vertical gain/position and horizontal delay to obtain a PASS on the Mask.

- 13 Measure the peak pulse amplitude at the mid pulse-width using the Oscilloscope and verify that this is nominally 560 mV.
- 14 Set the **TRANSMIT** signal to HIGH and check that the peak pulse amplitude is approximately 0.9V.
- 15 Set the **TRANSMIT** signal to LOW and check that the peak pulse amplitude is approximately 0.3V.

**Procedure - DSX-1**

**Positive Pulse**

- 1 Recall the HP 37718A/19A Default Settings as shown on page 3-4.
- 2 Connect the DSn 100Ω OUT port to the Oscilloscope via the HP 15508B Balanced to unbalanced Converter and terminate in 75Ω at the Oscilloscope input.
- 3 Select the Transmitter Output page.

Performance Tests  
**PDH/DSn Transmitter Output**

- 4 Set the **TRANSMIT** display as shown below.

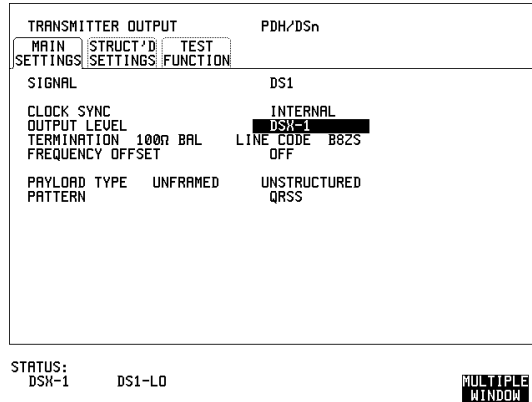

- 5 Select CHAN 1 on the Oscilloscope and set to 1MΩ input impedance.

**Load the Telecom Mask**

- 6 On the Oscilloscope, use the following key sequence to select and load the required Telecom Mask:
- SHIFT (Blue Key) APPLICATION.
  - TELECOM MASK/MASK** softkey.
  - Use ENTRY/MEASURE control to select DS1\_NEW in the highlighted MSK FILES window.
  - LOAD SETUP 8 M1M2** softkey.

**Compare Pulse with Mask**

- 7 On the Oscilloscope, use the following key sequence to compare the pulse with the mask:
- RECALL 8, (Ensure CH1 Impedance is reset to 1MΩ Select TRIGGER, SETUP and set **PATTERN TRIGGER** softkey to **Trig'd** ).
  - DEFINE MEAS
  - COMPARE** softkey
  - TEST ON** softkey
  - M1M2** softkey
  - AFTER FAIL CONTINUE** softkey
  - RUN

Performance Tests  
**PDH/DSn Transmitter Output**

---

**NOTE**

Using the balanced to unbalanced converter reduces the pulse amplitude by a factor of 1.266. This will cause the comparison with the mask to fail. To overcome this select CHAN 1 ON and reduce the Volts/Division setting (highlighted on the softkey display). Reduced Volts/Division = highlighted value/1.266. The new value can be entered using the keypad

---

- 8 The Oscilloscope will compare the positive pulse with the mask limits. A PASS message should appear on the Oscilloscope.

---

**NOTE**

It may be necessary to visibly fit the waveform to the mask by adjusting the Oscilloscope vertical position and horizontal delay to obtain a PASS on the Mask.

---

- 9 Measure the peak pulse amplitude at the mid pulse-width using the Oscilloscope and verify that this is between 1.896V and 2.844V.

**Negative Pulse**

- 10 On the Oscilloscope, use the following key sequence to access the inverted mask.
- a/ SHIFT (Blue Key) DISK
  - b/ **DIRECTORY** softkey
  - c/ Use ENTRY/MEASURE control to highlight INV\_MASK
  - d/ **CHANGE DIRECTORY** softkey

**Load the Telecom Mask**

- 11 On the Oscilloscope, use the following key sequence to select and load the required Telecom Mask:
- a/ SHIFT (Blue Key) APPLICATION.
  - b/ **TELECOM MASK/MASK** softkey.
  - c/ Use ENTRY/MEASURE control to select DS1\_NEW in the highlighted MSK FILES window.
  - d/ **LOAD SETUP 8 M1M2** softkey.

**Compare Pulse with Mask**

- 12 On the Oscilloscope, use the following key sequence to compare the pulse with the mask:
- a/ RECALL 8, (Ensure CH1 Impedance is reset to 1M $\Omega$  Select TRIGGER, SETUP and set **PATTERN TRIGGER** softkey to **Trig'd** ).
  - b/ DEFINE MEAS

Performance Tests  
**PDH/DSn Transmitter Output**

- c/ **COMPARE** softkey
- d/ **TEST ON** softkey
- e/ **M1M2** softkey
- f/ **AFTER FAIL CONTINUE** softkey
- g/ RUN

---

**NOTE**

Using the balanced to unbalanced converter reduces the pulse amplitude by a factor of 1.266. This will cause the comparison with the mask to fail. To overcome this select CHAN 1 ON and reduce the Volts/Division setting (highlighted on the softkey display). Reduced Volts/Division = highlighted value/1.266. The new value can be entered using the keypad

- 13** The Oscilloscope will compare the negative pulse with the mask limits. A PASS message should appear on the Oscilloscope.

---

**NOTE**

It may be necessary to visibly fit the waveform to the mask by adjusting the Oscilloscope vertical position and horizontal delay to obtain a PASS on the Mask.

- 14** Measure the peak pulse amplitude at the mid pulse-width using the Oscilloscope and verify that this is between 1.896V and 2.844V.
- 15** Set the **TRANSMIT** signal to LOW and check that the peak pulse amplitude reduces by approximately 20% and pulse shape has slower rise/fall edges.
- 16** Disconnect all the test equipment.

---

## PDH/DSn Receiver Equalization

### Specifications

Rate	Equalization
E1- 2.048 Mb/s	6dB for root f cable at 1/2 bit rate
E2 - 8.448 Mb/s	6dB for root f cable at 1/2 bit rate
E3 - 34.368 Mb/s	12dB for root f cable at 1/2 bit rate
E4 - 139.264 Mb/s	12dB for root f cable at 1/2 bit rate
DS1- 1.544 Mb/s	Single range from DS1-LO to DSX -1
DS3 - 44.736 Mb/s	Automatic equalization for up to 900 feet of root f cable.

---

#### NOTE

The Rates available are dependent on the HP 37718A/19A option

### Description

The Receiver Equalization is checked by looping the transmitter output to receiver input through a special Cable. This simulates the specified cable loss at the rate under test. A BER measurement is run and a check made for no errors in the results page.

### Equipment Required

<b>Cable Simulator E4</b>	80 metres of 8120-0049
<b>Cable Simulator E3</b>	120 metres of 8120-0049
<b>Cable Simulator E2</b>	80 metres of 8120-0049
<b>Cable Simulator E1</b>	120 metres of 8120-0049
<b>Cable Simulator DS3</b>	55 metres of 8120-0049
<b>Cable Simulator DS1</b>	80 metres of 8120-0049
<b>110Ω/75Ω Balanced to Unbalanced Converter</b>	HP 15508B (Qty 2)



Performance Tests  
PDH/DSn Receiver Equalization

### Procedure

- 1 Recall the HP 37718A/19A Default Settings as shown on page 3-4.
- 2 Select **SETTINGS CONTROL** TRANSMITTER and RECEIVER [COUPLED] on the **OTHER** display.

**139.264 Mb/s**

- 3 Set the **TRANSMIT** display as shown opposite

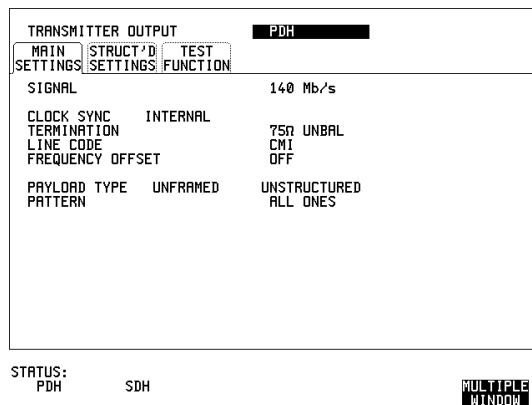

- 4 Connect Cable Simulator E4 between the PDH/DSn 75Ω OUT and 75Ω IN ports.
- 5 Press **RESULTS** **TROUBLE** **SCAN** then **RUN/STOP** to start the measurement.
- 6 Ensure that NO TROUBLE is displayed on the **RESULTS** display after 30 seconds.
- 7 Press **RUN/STOP** to stop the measurement.

Performance Tests  
PDH/DSn Receiver Equalization

**34.368 Mb/s**

8 Set the **TRANSMIT** display as shown below

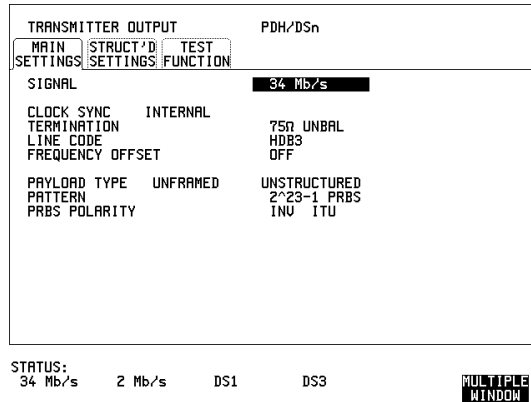

9 Connect Cable Simulator E3 between PDH/DSn 75Ω OUT and 75Ω IN ports.

10 Press **RESULTS** **TROUBLE** **SCAN** then **RUN/STOP** to start the measurement.

11 Ensure that NO TROUBLE is displayed on the **RESULTS** display after 30 seconds.

12 Press **RUN/STOP** to stop the measurement.

Performance Tests  
PDH/DSn Receiver Equalization

**DS3 (44.736 Mb/s)**

13 Set the **TRANSMIT** display as shown below.

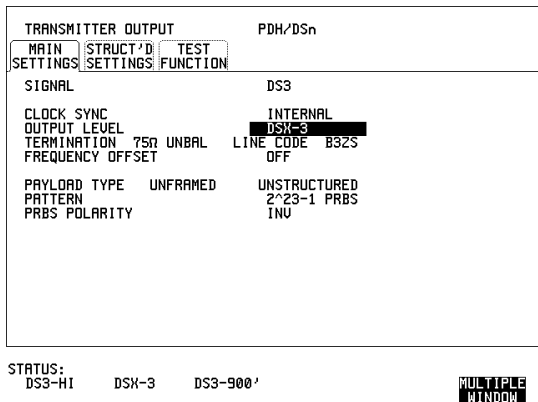

14 Connect Cable Simulator DS3 between the DSn 75Ω OUT and 75Ω IN ports.

15 Press **RESULTS** **TROUBLE** **SCAN** then **RUN/STOP** to start the measurement.

16 Ensure that NO TROUBLE is displayed on the **RESULTS** display after 30 seconds.

17 Press **RUN/STOP** to stop the measurement.

**NOTE**

If Cable Simulator DS3 is not available, it is permissible to select DS3-900' on the **TRANSMIT** display and connect the HP 37718A/19A 75Ω OUT port direct to the 75Ω IN port. This setup assumes the DS3-900' output signal is within specification.

Performance Tests  
PDH/DSn Receiver Equalization

**8.448 Mb/s**

18 Set the **TRANSMIT** display as shown below.

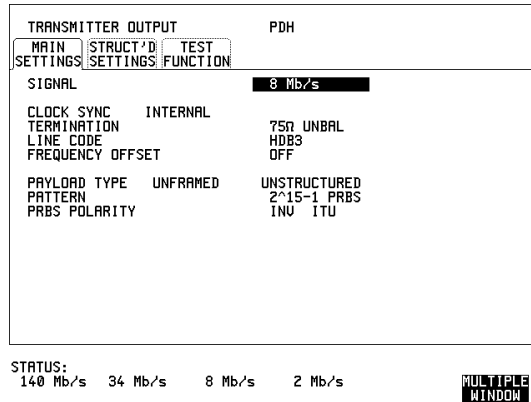

19 Connect Cable Simulator E2 between the PDH/DSn 75Ω OUT and 75Ω IN ports.

20 Press **RESULTS** **TROUBLE** **SCAN** then **RUN/STOP** to start the measurement.

21 Ensure that NO TROUBLE is displayed on the **RESULTS** display after 30 seconds.

22 Press **RUN/STOP** to stop the measurement.

Performance Tests  
PDH/DSn Receiver Equalization

2.048Mb/s

23 Set the **TRANSMIT** display as shown below.

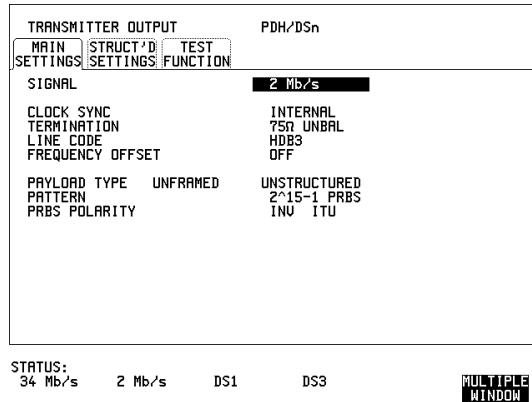

24 Connect Cable Simulator E1 between the PDH/DSn 75Ω OUT and 75Ω IN ports.

25 Press **RESULTS** **TROUBLE** **SCAN** then **RUN/STOP** to start the measurement.

26 Ensure that NO TROUBLE is displayed on the **RESULTS** display after 30 seconds.

27 Press **RUN/STOP** to stop the measurement.

Performance Tests  
PDH/DSn Receiver Equalization

**DS1 (1.544 Mb/s)**

28 Set the **TRANSMIT** display as shown below.

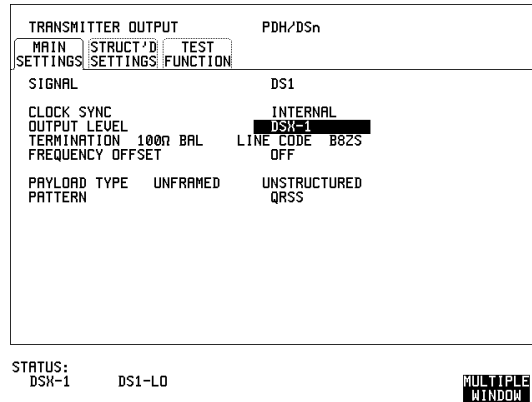

29 Connect Cable Simulator DS1 between the 110Ω OUT and 110Ω IN ports via two Balanced to Unbalanced Converters (HP 15508B).

30 Press **RESULTS** **TROUBLE** **SCAN** then **RUN/STOP** to start the measurement.

31 Ensure that NO TROUBLE is displayed on the **RESULTS** display after 30 seconds.

32 Press **RUN/STOP** to stop the measurement.

**NOTE**

If Cable Simulator DS1 is not available, it is permissible to select DS1-LO on the **TRANSMIT** display and connect the 110Ω OUT port direct to the 110Ω IN port. This setup assumes the DS1-LO output signal is within specification.

---

## **PDH/DSn Receiver Monitor Levels**

### **Specifications**

<b>Bit Rate</b>	<b>Nominal Loss</b>	<b>Equalization at 1/2 Bit Rate</b>
E1 - 2.048 Mb/s	20, 26, 30dB	3dB
E2 - 8.448 Mb/s	20, 26, 30dB	3dB
E3 - 34.368 Mb/s	20, 26dB	6dB
E4 - 139.264 Mb/s	20, 26dB	6dB
DS1 - 1.544 Mb/s	20, 26, 30dB	3dB
DS3 - 44.736 Mb/s	20, 26dB	6dB

---

**NOTE**

The Rates available are dependent on the HP 37718A/19A option

### **Description**

The signal from the HP 37718A/19A PDH Transmitter is applied to the PDH Receiver after attenuating by an amount equal to the selected Receiver Flat Loss plus the specified Cable Loss. The Flat Loss is obtained from a 75 $\Omega$  attenuator kit. The Cable Loss is supplied by inserting the correct Cable Simulators for each bit rate in the attenuation path.

### **Equipment Required**

<b>Cable Simulator E4-M</b>	40 metres of 8120-0049
<b>Cable Simulator E3-M</b>	60 metres of 8120-0049
<b>Cable Simulator E2-M</b>	40 metres of 8120-0049
<b>Cable Simulator E1-M</b>	60 metres of 8120-0049
<b>Cable Simulator DS3</b>	55 metres of 8120-0049
<b>Cable Simulator DS1</b>	80 metres of 8120-0049
<b>75<math>\Omega</math> Attenuator Kit</b>	HP 86213A
<b>Type N/BNC adaptors</b>	HP 1250-1534 & -1528 (2 off each)

Performance Tests  
**PDH/DSn Receiver Monitor Levels**

**Procedure**

- 1 Recall the HP 37718A/19A DEFAULT SETTINGS as shown on page 3-4.
- 2 Connect the equipment as shown in Figure 3-1.

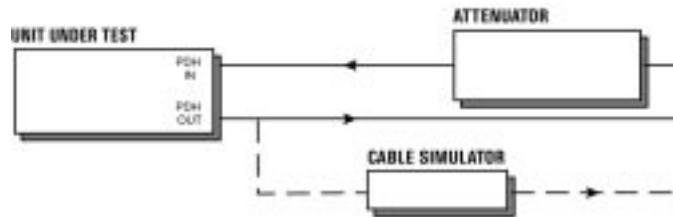

**Figure 3-1** Receiver Monitor Input Test Setup

**2.048 Mb/s (E1)**

- 1 Press **TRANSMIT** and set up the **MAIN SETTINGS** display as shown opposite.

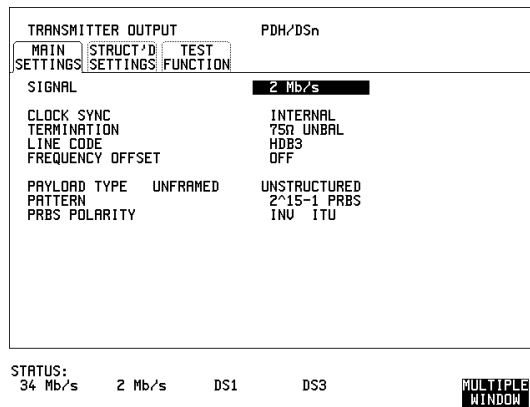

- 2 Press **RECEIVE** and set up the **MAIN SETTINGS** display as shown



## Performance Tests

### PDH/DSn Receiver Monitor Levels

below.

RECEIVER INPUT		PDH/DSn
MAIN SETTINGS	STRUCT'D SETTINGS	TEST FUNCTION
SIGNAL		2 Mb/s
TERMINATION		75Ω UNBAL
LINE CODE		HDB3
LEVEL		MONITOR
EQUALIZER	<b>OFF</b> GAIN	20 dB
PAYLOAD TYPE	UNFRAMED	UNSTRUCTURED
PATTERN		2 <sup>15</sup> -1 PRBS
PRBS POLARITY		INU ITU

STATUS:  
OFF                      ON

**MULTIPLE WINDOW**

- 3 Press **RESULTS** **TROUBLE SCAN**
- 4 Press **RUN/STOP** to start the measurement.
- 5 Ensure that NO TROUBLE is displayed on the **RESULTS** display after 30 seconds.
- 6 Press **RUN/STOP** to stop the measurement.
- 7 Press **RECEIVE** and select EQUALIZATION [ON] GAIN [20 dB].
- 8 Connect Cable Simulator E1-M between the PDH OUT Port and the attenuator.
- 9 Press **RESULTS** **TROUBLE SCAN** then **RUN/STOP** to start the measurement.
- 10 Ensure that NO TROUBLE is displayed on the **RESULTS** display after 30 seconds. Press **RUN/STOP** to stop the measurement.
- 11 Connect the 6dB Fixed Attenuator in the signal path to give a total path attenuation of 26dB.
- 12 Press **RECEIVE** and select MONITOR LEVEL [26dB].
- 13 Press **RESULTS**; **TROUBLE SCAN** then **RUN/STOP** to start the measurement.
- 14 Ensure that NO TROUBLE is displayed on the **RESULTS** display after 30 seconds. Press **RUN/STOP** to stop the measurement.
- 15 Remove Cable Simulator E1-M from the signal path.

## PDH/DSn Receiver Monitor Levels

- 16 Press **RECEIVE** and select EQUALIZATION [OFF].
- 17 Press **RESULTS**; **TROUBLE SCAN** then **RUN/STOP** to start the measurement.
- 18 Ensure that NO TROUBLE is displayed on the **RESULTS** display after 30 seconds. Press **RUN/STOP** to stop the measurement.
- 19 Remove the 6dB fixed attenuator and connect the 10dB Fixed Attenuator in the signal path to give a total path attenuation of 30dB.
- 20 Press **RECEIVE** and set MONITOR LEVEL [30dB].
- 21 Press **RESULTS** **TROUBLE SCAN** then **RUN/STOP** to start the measurement.
- 22 Ensure that NO TROUBLE is displayed on the **RESULTS** display after 30 seconds. Press **RUN/STOP** to stop the measurement.
- 23 Press **RECEIVE** and select EQUALIZATION [ON].
- 24 Connect Cable Simulator E1-M between the PDH OUT Port and the attenuator.
- 25 Press **RESULTS** **TROUBLE SCAN**. Press **RUN/STOP** to start the measurement.
- 26 Ensure that NO TROUBLE is displayed on the **RESULTS** display after 30 seconds. Press **RUN/STOP** to stop the measurement.

### 8.448 Mb/s (E2)

- 27 Repeat steps 1 to 26 (20dB, 26dB and 30dB tests) with the HP 37718A/19A **TRANSMIT** and **RECEIVE** displays set to SIGNAL [8 Mb/s] and Cable Simulator E2-M fitted in place of Cable Simulator E1-M.

### 34.368 Mb/s (E3)

- 28 Repeat steps 1 to 18 (20dB and 26dB tests) with the HP 37718A/19A **TRANSMIT** and **RECEIVE** displays set to SIGNAL [34 Mb/s] and Cable Simulator E3-M fitted in place of Cable Simulator E1-M.

### 139.264 Mb/s (E4)

- 29 Repeat steps 1 to 18 (20dB and 26dB tests) with the HP 37718A/19A **TRANSMIT** and **RECEIVE** displays set to SIGNAL [140 Mb/s] and Cable Simulator E4-M fitted in place of Cable Simulator E1-M.

## Performance Tests

### PDH/DSn Receiver Monitor Levels

#### 1.544 Mb/s (DS-1)

- 30** Repeat steps 1 to 26 (20dB, 26dB and 30dB tests) with the HP 37718A/19A **TRANSMIT** and **RECEIVE** displays set to SIGNAL [DSX-1]. Connect Cable Simulator DS1 between two Balanced to Unbalanced converters and fit in place of Cable Simulator E1-M.

#### 44.736 Mb/s (DS-3)

- 31** Repeat steps 1 to 18 (20dB and 26dB tests) with the HP 37718A/19A **TRANSMIT** and **RECEIVE** displays set to SIGNAL [DSX-3] and Cable Simulator DS3 fitted in place of Cable Simulator E1-M.
- 32** Disconnect all the test equipment.

---

## External Mux/Demux

### Specifications

Rate	Interface	Source
2.048 Mb/s (E1)	Meets ITU-T Rec. G.703 for unbalanced coaxial pair.	Accepts a 2 Mb/s Unbalanced signal conforming to ITU-T Rec. G.703.
1.544 Mb/s (DS-1)	Meets T1.102-1993 for Balanced pair.	Accepts a DS-1 balanced signal conforming to T1.102-1993.

---

#### NOTE

The Mux/Demux Rate available is dependent on the HP 37718A/19A option.

---

### Description

This test verifies operation of the PDH/DSn Mux and demux hardware and confirms the output characteristics of the external demux port on the PDH/DSn Receiver.

The *PDH/DSn Test Set* is set up to transmit an unframed 2Mb/s/DS-1 pattern. This is applied to the HP 37718A/19A INSERT Port. The 2Mb/s/DS-1 signal is multiplexed into a 34Mb/s/DS-3 data stream. The HP 37718A/19A transmitter and receiver are looped. The unframed 2Mb/s/DS-1 signal is Demultiplexed from the 34Mb/s/DS-3 data stream to the *PDH/DSn Test Set* via the HP 37718A/19A DROP port. A BER test is performed to verify the integrity of the 2 Mb/s/DS-1 signal.

The output from the DROP Port is then applied to an Oscilloscope, and the waveform characteristics are checked to ensure they meet specifications.

### Equipment Required

<b>Oscilloscope</b>	: HP 54520A Option 001
<b>PDH Test Set</b>	: HP 37718A/19A
<b>75Ω Termination</b>	: HP 15522-80010
<b>T Connector</b>	: HP 1250-0781

Performance Tests  
**External Mux/Demux**

---

**NOTE**

---

The *Test Set* used in this procedure is an 37718A/37719A. Any other PDH Test Set, capable of generating and measuring at 2 Mb/s/DS-1 unframed, can be used.

**Procedure**

**2Mb/s Mux/Demux**

- 1 Recall the HP 37718A/19A DEFAULT SETTINGS as shown on page 3-4.
- 2 Connect the equipment as shown in Figure 2.

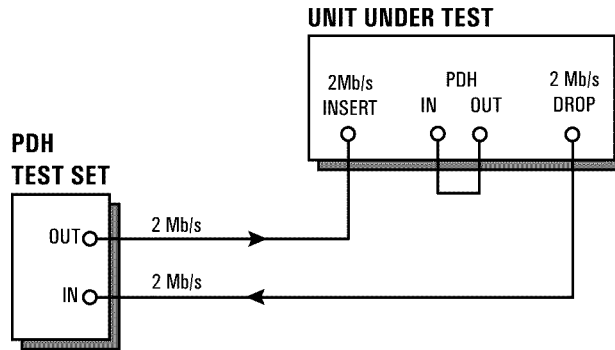

**Figure 2** External Mux/Demux Test Setup

Performance Tests  
**External Mux/Demux**

- 3 Press **TRANSMIT** on the *Test Set* and set up the display as shown below.

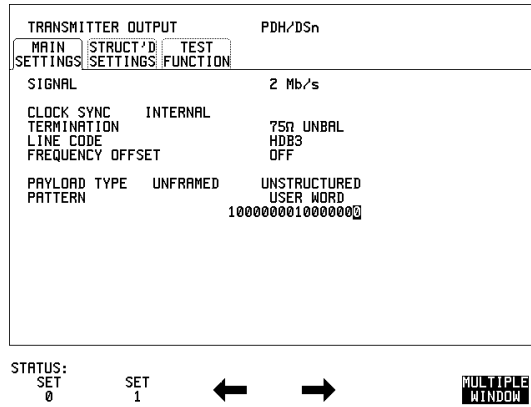

- 4 Press **RECEIVE** on the *Test Set* and set up the display as shown below.

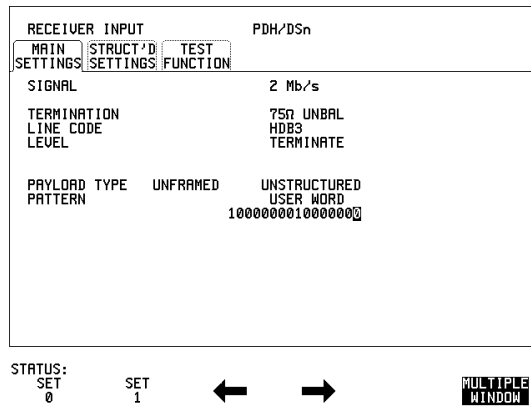

Performance Tests  
**External Mux/Demux**

- 5 Press **TRANSMIT** on the HP 37718A/19A and set up the **MAIN SETTINGS** display as shown below.

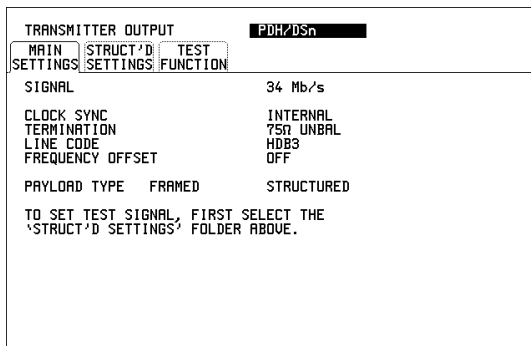

STATUS:

**MULTIPLE WINDOW**

- 6 Press **TRANSMIT** on the HP 37718A/19A and set up the **STRUCTURED SETTINGS** display as shown below.

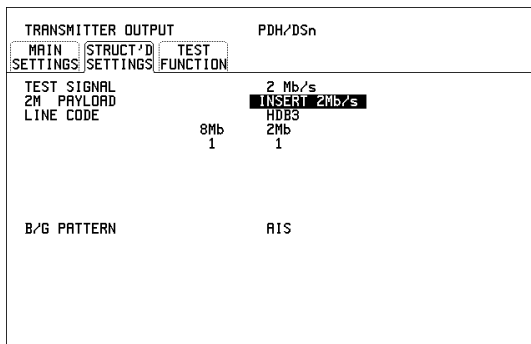

STATUS:

UNFRAMED    PCM30    PCM31    PCM30CRC    MORE    **MULTIPLE WINDOW**

Performance Tests  
**External Mux/Demux**

- 7 Press **RECEIVE** on the HP 37718A/19A and set up the **MAIN SETTINGS** display as shown below.

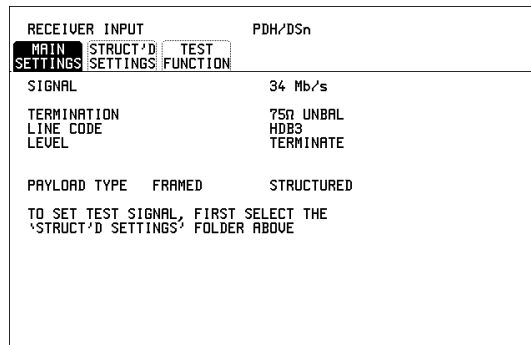

STATUS:

**MULTIPLE WINDOW**

- 8 Press **RECEIVE** on the HP 37718A/19A and set up the **STRUCTURED SETTINGS** display as shown below.

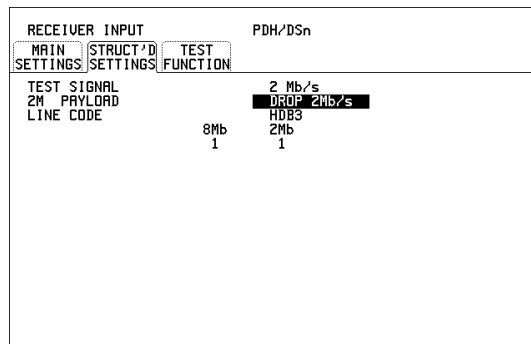

STATUS:

UNFRAMED

PCM30

PCM31

PCM30CRC

MORE

**MULTIPLE WINDOW**

- 9 Press **RUN/STOP** on the Test Set. Press **RESULTS TROUBLE SCAN** on the Test Set and ensure that **NO TROUBLE** is displayed.
- 10 Press **SINGLE** error add key on the Test Set and ensure the Bit Error count increments by one each time the key is pressed.



Performance Tests  
**External Mux/Demux**

**2.048 Mb/s Positive Pulse**

- 11 Disconnect the UUT 75Ω DROP port from the Test Set and connect to the Oscilloscope. Terminate in 75Ω at the Oscilloscope input.
- 12 Select CHAN 1 on the Oscilloscope and set to 1MΩ input impedance.

**Load the Telecom Mask**

- 13 On the Oscilloscope, use the following key sequence to select and load the required Telecom Mask:
  - a/ SHIFT (Blue Key) APPLICATION.
  - b/ **TELECOM MASK/MASK** softkey.
  - c/ Use ENTRY/MEASURE control to select DS\_1E in the highlighted MSK FILES window.
  - d/ **LOAD SETUP 8 M1M2** softkey.

**Compare Pulse with Mask**

- 14 On the Oscilloscope, use the following key sequence to compare the pulse with the mask:
  - a/ RECALL 8
  - b/ DEFINE MEAS
  - c/ **COMPARE** softkey
  - d/ **TEST ON** softkey
  - e/ **M1M2** softkey
  - f/ **AFTER FAIL CONTINUE** softkey
  - g/ RUN
- 15 The Oscilloscope will automatically display and compare an isolated positive pulse with the mask limits. A PASS message should appear on the Oscilloscope.

---

**NOTE**

---

It may be necessary to visibly fit the waveform to the mask by adjusting the Oscilloscope vertical position and horizontal delay to obtain a PASS on the Mask.

- 16 Measure the peak pulse amplitude at the mid pulse-width using the Oscilloscope and verify that this is between 2.133V and 2.607 Volts.

**2.048 Mb/s Negative Pulse**

- 17 On the Oscilloscope, use the following key sequence to access the inverted mask.
  - a/ SHIFT (Blue Key) DISK

Performance Tests  
**External Mux/Demux**

- b/ **DIRECTORY** softkey
- c/ Use ENTRY/MEASURE control to highlight INV\_MASK
- d/ **CHANGE DIRECTORY** softkey

**Load the Telecom Mask**

- 18** On the Oscilloscope, use the following key sequence to select and load the required Telecom Mask:
- a/ SHIFT (Blue Key) APPLICATION.
  - b/ **TELECOM MASK/MASK** softkey.
  - c/ Use ENTRY/MEASURE control to select DS\_1E in the highlighted MSK FILES window.
  - d/ **LOAD SETUP 8 M1M2** softkey.

**Compare Pulse with Mask**

- 19** On the Oscilloscope, use the following key sequence to compare the pulse with the mask:
- a/ RECALL 8
  - b/ DEFINE MEAS
  - c/ **COMPARE** softkey
  - d/ **TEST ON** softkey
  - e/ **M1M2** softkey
  - f/ **AFTER FAIL CONTINUE** softkey
  - g/ RUN
- 20** The Oscilloscope will automatically display and compare an isolated positive pulse with the mask limits. A PASS message should appear on the Oscilloscope.

---

**NOTE**

---

It may be necessary to visibly fit the waveform to the mask by adjusting the Oscilloscope vertical position and horizontal delay to obtain a PASS on the Mask.

- 21** Measure the peak pulse amplitude at the mid pulse-width using the Oscilloscope and verify that this is between 2.133V and 2.607 Volts.

**DS-1 Mux and Demux**

- 1** Connect the UUT balanced DS-1 Insert and Drop ports to the DS-1 Balanced Ports of the Test Set and repeat steps 3 through 10 substituting DS-1 for 2Mb/s and DS-3 for 34Mb/s.

Performance Tests  
**External Mux/Demux**

**DS-1 Positive Pulse**

- 2 Disconnect the UUT 100Ω DROP port from the Test Set and connect to the Oscilloscope via the HP 15508B Balanced to unbalanced Converter. Terminate in 75Ω at the Oscilloscope input.
- 3 Select CHAN 1 on the Oscilloscope and set to 1MΩ input impedance.

**Load the Telecom Mask**

- 4 On the Oscilloscope, use the following key sequence to select and load the required Telecom Mask:
  - a/ SHIFT (Blue Key) APPLICATION.
  - b/ **TELECOM MASK/MASK** softkey.
  - c/ Use ENTRY/MEASURE control to select DS1\_NEW in the highlighted MSK FILES window.
  - d/ **LOAD SETUP 8 M1M2** softkey.

**Compare Pulse with Mask**

- 5 On the Oscilloscope, use the following key sequence to compare the pulse with the mask:
  - a/ RECALL 8, (Ensure CH1 Impedance is reset to 1MΩ Select TRIGGER, SETUP and set **PATTERN TRIGGER** softkey to **Trig'd**).
  - b/ DEFINE MEAS
  - c/ **COMPARE** softkey
  - d/ **TEST ON** softkey
  - e/ **M1M2** softkey
  - f/ **AFTER FAIL CONTINUE** softkey
  - g/ RUN

---

**NOTE**

Using the balanced to unbalanced converter reduces the pulse amplitude by a factor of 1.266. This will cause the comparison with the mask to fail. To overcome this select CHAN 1 ON and reduce the Volts/Division setting (highlighted on the softkey display). Reduced Volts/Division = highlighted value/1.266. The new value can be entered using the keypad

---

- 6 The Oscilloscope will compare the positive pulse with the mask limits. A PASS message should appear on the Oscilloscope.

---

**NOTE**

It may be necessary to visibly fit the waveform to the mask by adjusting the Oscilloscope vertical position and horizontal delay to obtain a PASS on the Mask.

---

Performance Tests  
**External Mux/Demux**

- 7 Measure the peak pulse amplitude at the mid pulse-width using the Oscilloscope and verify that this is between 1.896V and 2.844V.

**DS-1 Negative Pulse**

- 8 On the Oscilloscope, use the following key sequence to access the inverted mask.
  - a/ SHIFT (Blue Key) DISK
  - b/ **DIRECTORY** softkey
  - c/ Use ENTRY/MEASURE control to highlight INV\_MASK
  - d/ **CHANGE DIRECTORY** softkey

**Load the Telecom Mask**

- 9 On the Oscilloscope, use the following key sequence to select and load the required Telecom Mask:
  - a/ SHIFT (Blue Key) APPLICATION.
  - b/ **TELECOM MASK/MASK** softkey.
  - c/ Use ENTRY/MEASURE control to select DS1\_NEW in the highlighted MSK FILES window.
  - d/ **LOAD SETUP 8 M1M2** softkey.

**Compare Pulse with Mask**

- 10 On the Oscilloscope, use the following key sequence to compare the pulse with the mask:
  - a/ RECALL 8, (Ensure CH1 Impedance is reset to  $1M\Omega$  Select TRIGGER, SETUP and set **PATTERN TRIGGER** softkey to **Trig'd**).
  - b/ DEFINE MEAS
  - c/ **COMPARE** softkey
  - d/ **TEST ON** softkey
  - e/ **M1M2** softkey
  - f/ **AFTER FAIL CONTINUE** softkey
  - g/ RUN

---

**NOTE**

Using the balanced to unbalanced converter reduces the pulse amplitude by a factor of 1.266. This will cause the comparison with the mask to fail. To overcome this select CHAN 1 ON and reduce the Volts/Division setting (highlighted on the softkey display). Reduced Volts/Division = highlighted value/1.266. The new value can be entered using the keypad

- 11 The Oscilloscope will compare the negative pulse with the mask limits. A PASS message should appear on the Oscilloscope.

Performance Tests  
**External Mux/Demux**

---

**NOTE**

---

It may be necessary to visibly fit the waveform to the mask by adjusting the Oscilloscope vertical position and horizontal delay to obtain a PASS on the Mask.

**12** Measure the peak pulse amplitude at the mid pulse-width using the Oscilloscope and verify that this is between 1.896V and 2.844V.

**13** Disconnect all test equipment.

## PDH/DSn Frequency Measurement and Looped Clock

### Specifications

<b>Accuracy</b>	4.5 ppm
<b>Measured Offset</b>	100 ppm

---

**NOTE** The Rates available are dependent on the HP 37718A/19A option

---

### Description

This test verifies that the HP 37718A/19A Receiver Frequency Measurement is within specified limits. These limits assume the instrument is within the calibration cycle.

A Synthesizer is used to generate a sinewave at half the data rate. This is applied to the HP 37718A/19A Receiver Signal In port. As this signal corresponds to an *All Ones Ternary Signal*, the HP 37718A/19A receiver should sync up with no errors if set to PATTERN [ALL ONES]. The Frequency Measurement accuracy of the HP 37718A/19A can be determined by comparison with the frequency displayed on the Synthesizer. Frequency Offset Measurement is also verified during this test as the HP 37718A/19A will display deviation from the expected Signal In frequency in ppm. The PDH transmitter recovered clock function is also verified at 2 Mb/s using the frequency counter in RATIO mode.

### Equipment Required

**Synthesizer** : HP 3335A Option 001 (75Ω)

**Frequency Counter** : HP 5335A Option 010

### Procedure

- 1 Recall the HP 37718A/19A DEFAULT SETTINGS as shown on page 3-4.
- 2 Connect up the equipment as shown in Figure 3-3.

Performance Tests  
**PDH/DSn Frequency Measurement and Looped Clock**

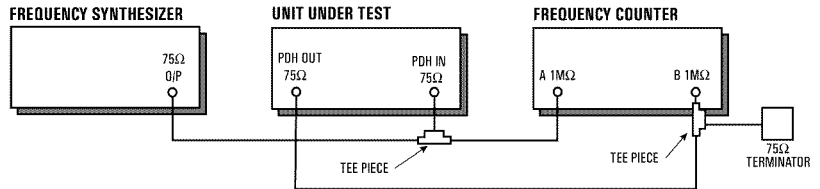

**Figure 3-3 Receiver Frequency Measurement Test Setup**

- 3 Set the Synthesizer to:  
 FREQUENCY - 1024.000 KHz sinewave  
 AMPLITUDE - +10dBm.
- 4 Set the frequency counter to RATIO A/B.
- 5 Press **RECEIVE** and set up the display as shown below.

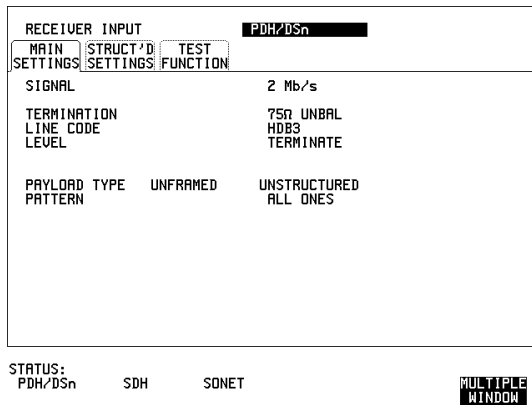

## Performance Tests

### PDH/DSn Frequency Measurement and Looped Clock

- 6 Press **TRANSMIT** and set up the display as shown below.

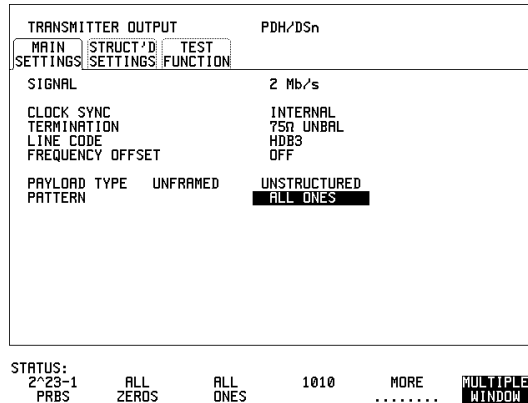

- 7 Press **RESULTS** and set up the display as shown below.

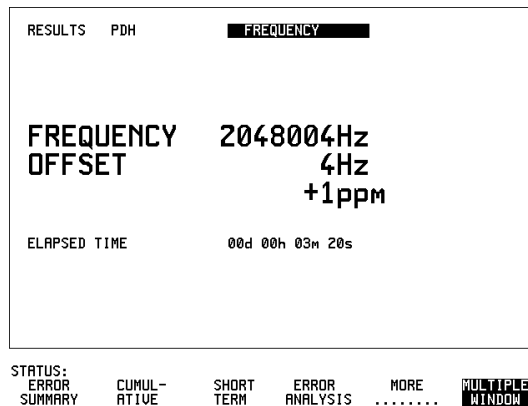

- 8 Verify that the FREQUENCY displayed is between 2047991 Hz and 2048009 Hz.
- 9 Verify that the Offset displayed is between +4.5 ppm and -4.5 ppm.
- 10 Set the synthesizer frequency to 1024.102 kHz and verify that the



## Performance Tests

### PDH/DSn Frequency Measurement and Looped Clock

frequency displayed on the **RESULTS** display is between 2048.194 kHz and 2048.214 kHz.

- 11 Verify that the Offset displayed is between 95.5 ppm and 104.5 ppm. The frequency counter should read 1.00.
- 12 Set the synthesizer frequency to 1023.898 kHz and verify that the frequency displayed on the **RESULTS** display is between 2047.786 kHz and 2047.806 kHz.
- 13 Verify that the Offset displayed is between -95.5 ppm and -104.5 ppm. The frequency counter should read 1.00.
- 14 Set the synthesizer level to +10 dBm, synthesizer frequency and the HP 37718A/19A to the settings given in Table 3-1 and verify the displayed Offset at each point.

**Table 3-1 PDH/DSn Offsets**

Receive Frequency	Synthesizer Frequency	Displayed Offset
8 Mb/s (E2)	4224,000 Hz	-4.5 to +4.5 ppm
8 Mb/s (E2)	4223,578 Hz	-95.5 to -104.5 ppm
8 Mb/s (E2)	4224,422 Hz	+95.5 to +104.5 ppm
34 Mb/s (E3)	17,184,000 Hz	-4.5 to +4.5 ppm
34 Mb/s (E3)	17,182,282 Hz	-95.5 to -104.5 ppm
34 Mb/s (E3)	17,185,718 Hz	+95.5 to +104.5 ppm
140 Mb/s (E4)	69,632,000 Hz	-4.5 to +4.5 ppm
140 Mb/s (E4)	69,625,036 Hz	-95.5 to -104.5 ppm
140 Mb/s (E4)	69,638,963 Hz	+95.5 to +104.5 ppm
1.544 Mb/s (DS-1)	772,000 Hz	-4.5 to +4.5 ppm
1.544 Mb/s (DS-1)	771,923 Hz	-95.5 to -104.5 ppm
1.544 Mb/s (DS-1)	772,077 Hz	+95.5 to +104.5 ppm
44.736 Mb/s (DS-3)	22,368,000 Hz	-4.5 to +4.5 ppm
44.736 Mb/s (DS-3)	22,365,763 Hz	-95.5 to -104.5 ppm
44.736 Mb/s (DS-3)	22,370,237 Hz	+95.5 to +104.5 ppm

## **SDH/SONET Transmitter Clock Accuracy**

### **Specification**

<b>Bit Rate</b>	<b>Accuracy</b>
51.84 Mb/s	4.5 ppm

### **Description**

The test uses a Frequency Counter connected to the Multirate Analyzer module Clock Trigger output port. This output is derived from the Clock module internal 10MHz clock oscillator providing a 51.84 MHz that is directly related to all SDH/SONET output rates.

### **Equipment Required**

**Frequency Counter** : HP 5335A Option 010

### **Procedure**

- 1 Recall the HP 37718A/19A DEFAULT SETTINGS as shown on page 3-4.
- 2 Set the Transmitter Output to SDH/SONET.
- 3 Connect the HP 37718A/19A Multirate Analyzer module CLOCK TRIGGER port to the Frequency Counter Input A, set the input termination to 50 $\Omega$ .
- 4 Adjust the Frequency Counter Trigger Level to obtain a stable reading and ensure that the Frequency Counter reads between 51.839670 MHz and 51.840230 MHz.
- 5 Disconnect all the test equipment.

---

## External Clock/Data Reference Inputs & Clock Reference Output

### Specifications

Clock Rate	Description
2.048 Mb/s MTS	Accepts timing reference as per ITU-T G.811
10 MHz Reference	Accepts 10 MHz timing reference
1.544 Mb/s BITS	Accepts DS-1 timing reference as per TA-TSY-000378
64 kb/s	Accepts 64 kb/s timing reference as per ITU-T G.703 Section 1.2.2
STM-1/STS-3 Receive	Recovers clock from received STM/STS input signal.

---

#### NOTE

The Rates available are dependent on the HP 37718A/19A option

#### Description

This test verifies that signal integrity is maintained when an EXTERNAL clock is used as a reference.

#### Equipment Required

<b>Synthesizer</b>	: HP 3335A option 001 (75 $\Omega$ )
<b>PDH/DSn Test Set</b>	: HP 37718A/19A
<b>110<math>\Omega</math>/75<math>\Omega</math> Balanced to Unbalanced Converter</b>	: HP 15508B
<b>Frequency Counter</b>	: HP 5335A Opt 010
<b>64kb/s Test Set</b>	: HP 37732A

## Performance Tests

### External Clock/Data Reference Inputs & Clock Reference Output

#### Procedure

##### MTS Clock - Clock Format

- 1 Connect the 52/155 Mb/s DATA OUT port to the 52/155 Mb/s DATA IN port.
- 2 Recall the HP 37718A/19A Default Settings as shown on page 3-4 and set the **OTHER** **SETTINGS** **CONTROL** display as shown below.

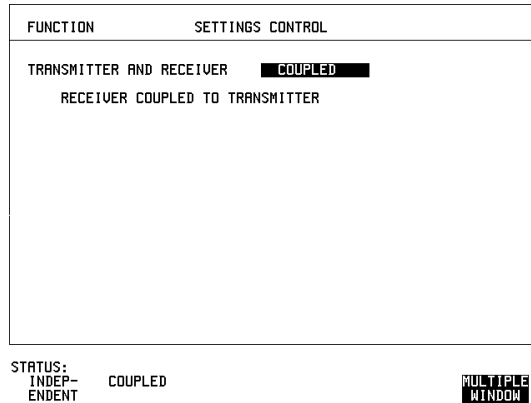

- 3 Press **TRANSMIT** and set up the display as shown below.

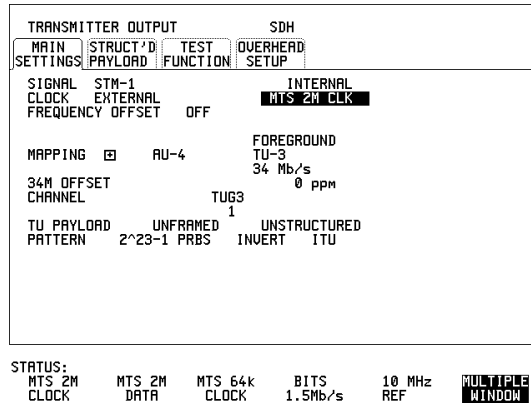

- 4 Set the HP 3335A to 2.048 MHz at +10 dBm.

## Performance Tests

### External Clock/Data Reference Inputs & Clock Reference Output

- 5 Connect the HP 3335A to the HP 37718A/19A 75Ω 2M REF IN port on the Clock module.
- 6 Press **RESULTS**; **TROUBLE SCAN** .
- 7 Press **RUN/STOP**, check that the display reads NO TROUBLE and all the Alarm leds are off.
- 8 Press **RUN/STOP** to halt the measurement.

### Clock REF OUT

- 9 Connect the Clock REF Out port to the Frequency Counter and check that a 2.048MHz signal is present.

### MTS Clock - Data

- 10 Disconnect the HP 3335A Synthesizer from the HP 37718A/19A 75Ω 2M REF IN port.
- 11 Set the PDH/DSn Test Set to transmit a 2 Mb/s unframed signal.
- 12 Connect the PDH/DSn Test Set, 75Ω Output to the HP 37718A/19A 75Ω 2M REF IN Port and Recall the DEFAULT SETTINGS as shown on page 3-4.
- 13 Set the **TRANSMIT** display as shown below.

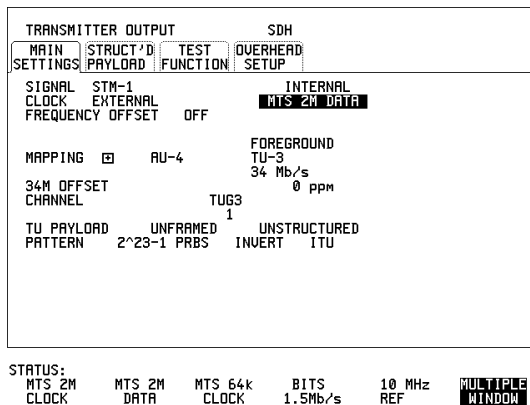

- 14 Select CLOCK SYNC FORMAT [2 Mb/s DATA] on the SDH **TRANSMIT** Display.

- 15 Press **RESULTS** **TROUBLE SCAN** then **RUN/STOP**.

## External Clock/Data Reference Inputs & Clock Reference Output

- 16 Check that the **RESULTS** Display reads NO TROUBLE and all the Alarm LEDs are off. Press **RUN/STOP** to halt the measurement.
- 17 Disconnect the PDH/DSn Test Set, 75Ω 2 Mb/s PDH Output from the 75Ω 2M REF IN Port.
- 18 Connect the PDH/DSn Test Set, 120Ω 2 Mb/s PDH Output to the 120Ω 2M REF IN Port.
- 19 Change the PDH O/P termination to 120Ω on the PDH/DSn Test Set and the HP 37718A/19A.
- 20 Press **RESULTS** **TROUBLE SCAN** then **RUN/STOP** on the HP 37718A/19A.
- 21 Check that the **RESULTS** Display reads NO TROUBLE and all the Alarm LEDs are off. Press **RUN/STOP** to halt the measurement.

### STM-1/STS-3 Receive Data

- 22 Disconnect the PDH/DSn Test Set Data Output from the HP 37718A/19A, 120Ω 2M REF IN port.
- 23 Disconnect the 52/155 Mb/s DATA OUT port from the 52/155 Mb/s DATA IN port
- 24 Select CLOCK SYNC [STM-1/STS-3 RECEIVE] ON THE HP 37718A/19A **TRANSMIT** display.
- 25 The SDH Clock Loss Alarm led should be lit on the HP 37718A/19A.
- 26 Set the Synthesizer frequency to 77.760MHz and amplitude to +10dBm.
- 27 Connect the Synthesizer to the 75Ω 52/155 Mb/s DATA IN port.
- 28 Ensure that the SDH/SONET Clock Loss Alarm Led is not lit.

---

#### NOTE

As the signal is unframed the LOF/OOF etc. alarms will be on.

### 10 MHz Reference

- 29 Select CLOCK SYNC [10MHz REF] ON THE HP 37718A/19A **TRANSMIT** display.
- 30 The SDH/SONET Clock Loss Alarm led should be lit on the HP 37718A/19A.
- 31 Set the Synthesizer frequency to 10.000MHz and amplitude to +10dBm.

## Performance Tests

### External Clock/Data Reference Inputs & Clock Reference Output

**32** Connect the Synthesizer to the HP 37718A/19A, 75 $\Omega$  2M REF IN Port.

**33** Ensure that the SDH/SONET Clock Loss Alarm Led is not lit.

#### **BITS Clock**

**34** Select CLOCK SYNC [BITS] ON THE HP 37718A/19A **TRANSMIT** display.

**35** The SDH/SONET Clock Loss Alarm led should be lit on the HP 37718A/19A.

**36** Set the Synthesizer frequency to 772kHz and amplitude to +10dBm.

**37** Connect the Synthesizer, via the Balanced to Unbalanced converter, to the HP 37718A/19A, 100 $\Omega$  BITS Clock Port.

**38** Ensure that the SDH/SONET Clock Loss Alarm Led is not lit.

#### **64 kb/s Clock**

**39** Select CLOCK SYNC [64 kb/s] ON THE HP 37718A/19A **TRANSMIT** display.

**40** The SDH/SONET Clock Loss Alarm led should be lit on the HP 37718A/19A.

**41** Set the 64kb/s Test Set to provide a 64kb/s Clock Signal.

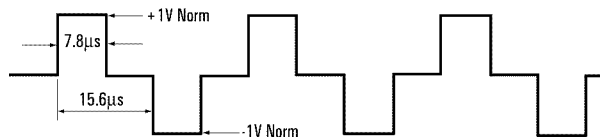

Suitable 64kb/s AMI signal (into 100/120 ohms balanced)  
if 64kb/s Test set is not available.  
Signal must be derived from a stable synthesized source.

**42** Connect the Clock Signal to the HP 37718A/19A balanced 64K Clock input.

**43** Ensure that the SDH/SONET Clock Loss Alarm Led is not lit.

**44** Disconnect all the test equipment.

## SDH/SONET Frequency Offsets

### Specifications

<b>Range</b>	±999 ppm
<b>Resolution</b>	0.1 ppm
<b>Accuracy</b>	0.02 ppm

### Description

The test uses a Frequency Counter connected to the Multirate Analyzer module Clock Trigger output port. This output is derived from the Clock module and is directly related to the SDH/SONET output rate. An external 10 MHz reference from a Signal Generator is used to clock the HP 37718A/19A and also provides a timebase reference for the Frequency counter. The counter measures the Clock Trigger frequency to check the offset accuracy and range.

### Equipment Required

<b>Signal Generator</b>	: HP 8657A
<b>Frequency Counter</b>	: HP 5335A Opt 010
<b>T Connector</b>	: HP 1250-0781

### Procedure

- 1 Recall the HP 37718A/19A DEFAULT SETTINGS as shown on page 3-4. Set the Transmitter Output to SDH/SONET.
- 2 Select CLOCK SYNC [10MHz REF] ON THE HP 37718A/19A **TRANSMIT** display.
- 3 Connect the HP8657A to the HP 37718A/19A Unbalanced 75Ω 2M REF IN port on the Clock Module.
- 4 Set the Signal Generator frequency to 10.000MHz and amplitude to +10dBm.
- 5 Check the Clock Loss Alarm Led is not lit.



## Performance Tests

### SDH/SONET Frequency Offsets

- 6 Connect the Signal Generator, Timebase OUT port (rear panel), to the counter Timebase IN port (rear panel).
- 7 Check the Counter EXT TIME BASE flag is illuminated on the front panel.
- 8 Connect the HP 37718A/19A Multirate Analyzer module CLOCK TRIGGER port to the Frequency Counter, set input termination to  $50\Omega$
- 9 Adjust the Frequency Counter Trigger Level to obtain a stable reading.
- 10 The reading should be between 51.839999 - 51.840001MHz. If not check setup and ensure the Counter is locked to the Signal Generator.
- 11 Set the HP 37718A/19A frequency offset to the settings given in Table 3-2 and verify the frequency at each step is within the Min/Max limits.

---

**Table 3-2**                      **SDH/SONET Offset**

<b>Offset (ppm)</b>	<b>Min Expected Frequency</b>	<b>Max Expected Frequency</b>
-999ppm	51788210.8 Hz	51788212.9 Hz
-100ppm	51834814.9 Hz	51834817.1 Hz
-66.6ppm	51836546.4 Hz	51836548.5 Hz
+33.3ppm	51841725.2 Hz	51841727.3 Hz
+100ppm	51845182.9 Hz	51845185.1 Hz
+999ppm	51891787.1 Hz	51891789.2 Hz

- 12 Disconnect all the test equipment.

## **STM-0/STS-1 Transmitter Output Waveshape**

### **Specifications**

<b>Level</b>	<b>Pulse Amplitude &amp; Shape</b>
Cross-Connect (450 feet)	530 mV peak (nominal). Compliant with GR-253, Issue 1, Figure 4-10 and draft recommendation ITU-R F.750, Appendix1
HIGH	1 V peak (nominal)
LOW	300 mV peak (nominal)

### **Description**

An Oscilloscope is connected to the HP 37718A/19A Transmitter STM-0/STS-1 output and used to check the STM-0/STS-1 waveshape against the relevant mask.

### **Equipment Required**

**Oscilloscope** : HP 54520A Option 001  
**75Ω Termination** : HP 15522-80010  
**T Connector** : HP 1250-0781

### **Procedure**

#### **Positive Pulse**

- 1 Recall HP 37718A/19A DEFAULT SETTINGS as shown on page 3-4 and set up the **TRANSMIT** display as shown on the following page.

## Performance Tests

### STM-0/STS-1 Transmitter Output Waveshape

TRANSMITTER OUTPUT		SDH	
MAIN SETTINGS	STRUCT'D PAYLOAD	TEST FUNCTION	OVERHEAD SETUP
SIGNAL	STM-0	X-CON	INTERNAL
CLOCK	INTERNAL		
FREQUENCY OFFSET	OFF		
MAPPING	<input checked="" type="checkbox"/> AU-3	FOREGROUND	UC-3
34M OFFSET			34 Mb/s
			0 ppm
PAYLOAD TYPE	UNFRAMED	UNSTRUCTURED	
PATTERN	2^23-1 PRBS	INVERT	ITU

STATUS: CROSS-CONNECT      HIGH      LOW      **MULTIPLE WINDOW**

- 2 Connect the 52/155 Mb/s 75Ω DATA OUT port to the Oscilloscope CHAN 1, terminate in 75Ω
- 3 Select CHAN 1 on the Oscilloscope and set to 1MΩ input impedance.

#### Load the Telecom Mask

- 4 On the Oscilloscope, use the following key sequence to select and load the required Telecom Mask:
  - a/ SHIFT (Blue Key) APPLICATION.
  - b/ **TELECOM MASK/MASK** softkey.
  - c/ Use ENTRY/MEASURE control to select STS1\_93 in the highlighted MSK FILES window.
  - d/ **LOAD SETUP 8 M1M2** softkey.

#### Compare Pulse with Mask

- 5 On the Oscilloscope, use the following key sequence to compare the pulse with the mask:
  - a/ RECALL 8
  - b/ DEFINE MEAS
  - c/ **COMPARE** softkey
  - d/ **TEST ON** softkey
  - e/ **M1M2** softkey
  - f/ **AFTER FAIL CONTINUE** softkey
  - g/ RUN
- 6 The Oscilloscope will automatically display and compare an isolated positive pulse with the mask limits. A PASS message should appear on the Oscilloscope.

## STM-0/STS-1 Transmitter Output Waveshape

---

### NOTE

---

It may be necessary to select **MASK** softkey and **MASK AUTO** / **MASK ALIGN** or to visibly fit the waveform to the mask by adjusting the Oscilloscope vertical gain/position and horizontal delay to obtain a PASS on the Mask.

- 7 Measure the peak pulse amplitude at the mid pulse-width using the Oscilloscope and verify that this is nominally 530 mV.

### Negative Pulse

- 8 On the Oscilloscope, use the following key sequence to access the inverted mask.
  - a/ SHIFT (Blue Key) DISK
  - b/ **DIRECTORY** softkey
  - c/ Use ENTRY/MEASURE control to highlight INV\_MASK
  - d/ **CHANGE DIRECTORY** softkey

### Load the Telecom Mask

- 9 On the Oscilloscope, use the following key sequence to select and load the required Telecom Mask:
  - a/ SHIFT (Blue Key) APPLICATION.
  - b/ **TELECOM MASK/MASK** softkey.
  - c/ Use ENTRY/MEASURE control to select STS1\_93 in the highlighted MSK FILES window.
  - d/ **LOAD SETUP 8 M1M2** softkey.

### Compare Pulse with Mask

- 10 On the Oscilloscope, use the following key sequence to compare the pulse with the mask:
  - a/ RECALL 8
  - b/ DEFINE MEAS
  - c/ **COMPARE** softkey
  - d/ **TEST ON** softkey
  - e/ **M1M2** softkey
  - f/ **AFTER FAIL CONTINUE** softkey
  - g/ RUN
- 11 The Oscilloscope will automatically display and compare an isolated positive pulse with the mask limits. A PASS message should appear on the Oscilloscope

**STM-0/STS-1 Transmitter Output Waveshape**

---

**NOTE**

---

It may be necessary to select **MASK** and **MASK AUTO / MASK ALIGN** to visibly fit the waveform to the mask by adjusting the Oscilloscope vertical gain/position and horizontal delay to obtain a PASS on the Mask.

- 12** Measure the peak pulse amplitude at the mid pulse-width using the Oscilloscope and verify that this is nominally 530 mV.
- 13** Change the signal to STM-0/STS-1 HIGH and check that the +ve and -ve pulses are nominally 1 V.
- 14** Change the signal to STM-0/STS-1 LOW and check that the +ve and -ve pulses max) peaks are nominally 300 mV.

## STM-1/STS-3 Transmitter Output Waveshape

### Specifications

<b>Pulse Shape</b>	Meets ITU Recommendation G.703
<b>Amplitude</b>	$\pm 0.5V \pm 10\%$

### Description

An Oscilloscope is connected to the HP 37718A/19A Transmitter STM-1/STS-3 output and used to view the waveforms with All Ones and All Zeros patterns selected in turn. The displayed waveshape is checked against the relevant mask. The STM/STS Framing is disabled during this test.

### Equipment Required

**Oscilloscope** : HP 54520A - option 001  
**75Ω Termination** : HP 15522-80010  
**T Connector** : HP 1250-0781

### Procedure

---

**NOTE**

---

This performance test is written using the HP 54520A Oscilloscope with Option 001 - Telecom Masks Application. If any other Oscilloscope is used the keystrokes given in this procedure will not apply.

#### Installing the Telecom Masks Option

- 1 Insert the Disk containing the Telecom Mask into the Oscilloscope Disk Drive.
- 2 Press **SHIFT** (Blue Key) **DISK**
- 3 Press **DIRECTORY** then **ROOT DIRECTORY**.

### STM-1/STS-3 Transmitter Output Waveshape

#### All Ones Pulse

- 1 Connect up the equipment as shown in Figure 3-4 and Recall HP 37718A/19A DEFAULT SETTINGS as shown on page 3-4.

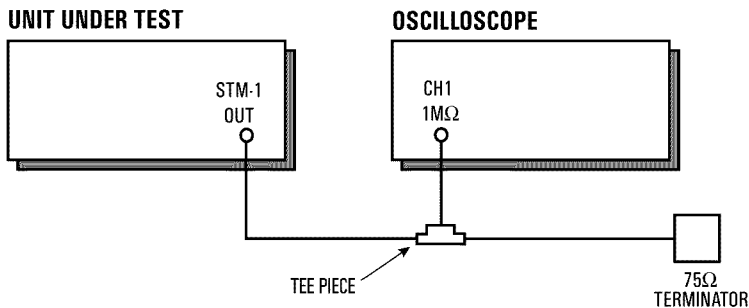
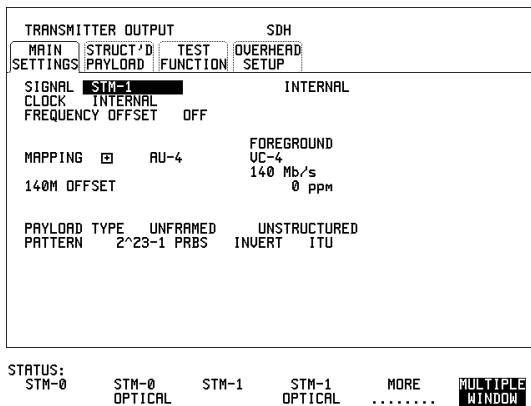

Figure 3-4

#### STM-1/STS-3 Transmitter Output Waveshape Test Setup

- 2 Press **TRANSMIT** and set up the display as shown below.



## Performance Tests

### STM-1/STS-3 Transmitter Output Waveshape

- 3 Press **OTHER** **CALIBRATION** and enter the calibration password - 1243. Set up the display as shown opposite.

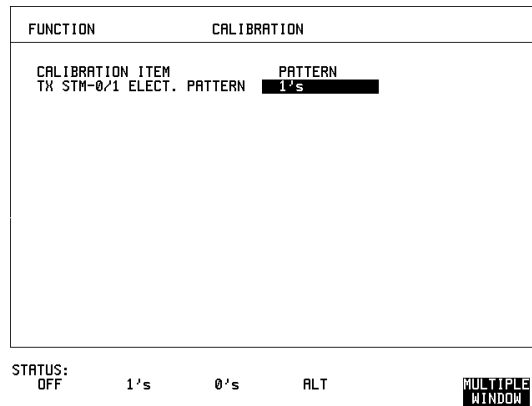

- 4 Connect the 52/155 Mb/s 75Ω DATA OUT port to the Oscilloscope, terminate in 75Ω
- 5 Select CHAN on the Oscilloscope and set to 1MΩ input impedance.

#### Load the Telecom Mask

- 6 On the Oscilloscope, use the following key sequence to select and load the required Telecom Mask:
  - a/ SHIFT (Blue Key) APPLICATION.
  - b/ **TELECOM MASK/MASK** softkey.
  - c/ Use ENTRY/MEASURE control to select 155BIN1 in the highlighted MSK FILES window.
  - d/ **LOAD SETUP 8 M1M2** softkey.

#### Compare Pulse with Mask

- 7 On the Oscilloscope, use the following key sequence to compare the pulse with the mask:
  - a/ RECALL 8, (Ensure CH1 Impedance is reset to 1MΩ)
  - c/ **COMPARE** softkey
  - d/ **TEST ON** softkey
  - e/ **M1M2** softkey
  - f/ **AFTER FAIL CONTINUE** softkey
  - g/ RUN



## STM-1/STS-3 Transmitter Output Waveshape

- 8 The Oscilloscope will automatically display and compare an isolated positive pulse with the mask limits. A PASS message should appear on the Oscilloscope.

---

### NOTE

---

It may be necessary to visibly fit the waveform to the mask by adjusting the Oscilloscope vertical position and horizontal delay to obtain a PASS on the Mask.

- 9 Measure the peak pulse amplitude at the mid pulse-width using the Oscilloscope and verify that this is between 450 mV and 550 mV. (i.e. 900 mV-1.1V Pk-Pk)

### All 0's Pulse

- 10 Select PATTERN [ALL 0's] on the **OTHER** **CALIBRATION** display.

### Load the Telecom Mask

- 11 On the Oscilloscope, use the following key sequence to select and load the required Telecom Mask:
  - a/ SHIFT (Blue Key) APPLICATION.
  - b/ **TELECOM MASK/MASK** softkey.
  - c/ Use ENTRY/MEASURE control to select 155BIN0 in the highlighted MSK FILES window.
  - d/ **LOAD SETUP 8 M1M2** softkey.

### Compare Pulse with Mask

- 12 On the Oscilloscope, use the following key sequence to compare the pulse with the mask:
  - a/ RECALL 8, (Ensure CH1 Impedance is reset to 1M $\Omega$ )
  - b/ DEFINE MEAS
  - c/ **COMPARE** softkey
  - d/ **TEST ON** softkey
  - e/ **M1M2** softkey
  - f/ **AFTER FAIL CONTINUE** softkey
  - g/ RUN
- 13 The Oscilloscope will automatically display and compare an isolated positive pulse with the mask limits. A PASS message should appear on the Oscilloscope.

**STM-1/STS-3 Transmitter Output Waveshape**

---

**NOTE**

---

It may be necessary to visibly fit the waveform to the mask by adjusting the Oscilloscope vertical position and horizontal delay to obtain a PASS on the Mask.

- 14** Measure the peak pulse amplitude at the mid pulse-width using the Oscilloscope and verify that this is between 450 mV and 550 mV. (i.e. 900 mV-1.1V Pk-Pk)
- 15** On the Oscilloscope, use the following key sequence to access the inverted mask.
  - a/ SHIFT (Blue Key) DISK
  - b/ **DIRECTORY** softkey
  - c/ Use ENTRY/MEASURE control to highlight INV\_MASK
  - d/ **CHANGE DIRECTORY** softkey
- 16** Repeat steps 6 to 14 to check pulses against Inverted masks.
- 17** Set CALIBRATION PATTERN to OFF and disconnect all the test equipment.

## **SDH/SONET Receiver Equalization**

### **Specifications**

<b>Rate</b>	<b>Equalization</b>
STM-0/STS-1 - 51.84 Mb/s	12dB for root f cable at 1/2 bit rate
STM-1/STS-3 - 155.52 Mb/s	12dB for root f cable at 1/2 bit rate

### **Description**

The Receiver Equalization is checked by looping the transmitter output to receiver input through a special Cable Simulator. This device is designed to simulate the specified cable loss at the rate under test. A BER measurement is run and a check made for no errors in the results page.

### **Equipment Required**

**Cable Simulator STM-0/STS-1** 50 metres of 8120-0049

**Cable Simulator STM-1/STS-3** 75 metres of 8120-0049

### **Procedure**

#### **STM-0/STS-1**

- 1 Recall the HP 37718A/19A Default Settings as shown on page 3-4 and set the **OTHER** **SETTINGS** **CONTROL** display as shown on the following page.

Performance Tests  
**SDH/SONET Receiver Equalization**

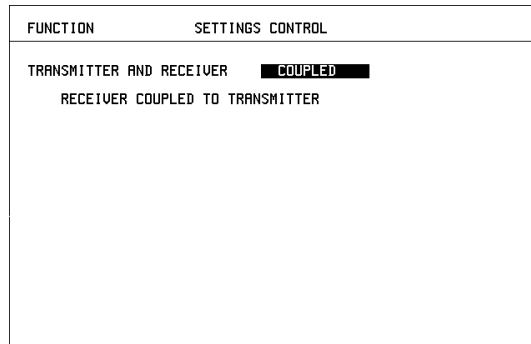

STATUS:  
 INDEP-  
 ENDENT      COUPLED

MULTIPLE  
 WINDOW

2 Set the **TRANSMIT** display as shown below.

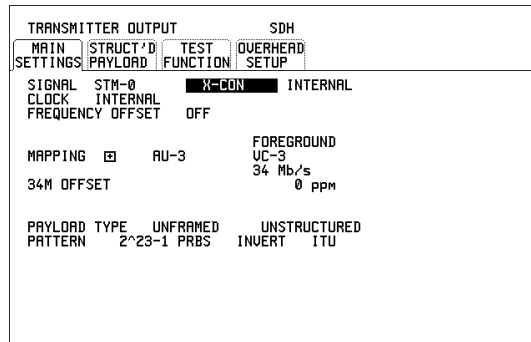

STATUS:  
 CROSS-  
 CONNECT      HIGH      LOW

MULTIPLE  
 WINDOW

- 3 Connect Cable Simulator STS-1 between the 52/155 Mb/s 75Ω DATA OUT and 52/155 Mb/s 75Ω DATA IN ports.
- 4 Press **RESULTS** **TROUBLE** **SCAN** then **RUN/STOP** to start the measurement.
- 5 Ensure that NO TROUBLE is displayed on the **RESULTS** display after 30 seconds.
- 6 Press **RUN/STOP** to stop the measurement.

Performance Tests  
**SDH/SONET Receiver Equalization**

**Procedure**

**STM-1/STS-3**

Set the **TRANSMIT** display as shown below.

7

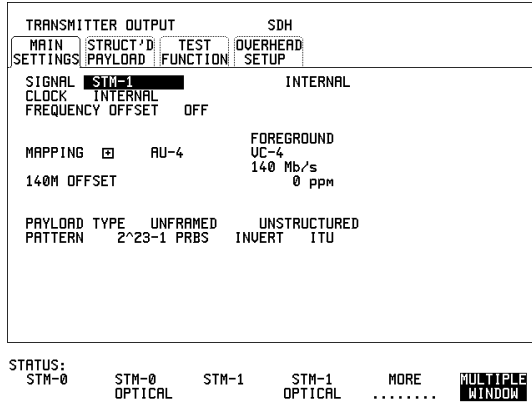

- 8 Connect Cable Simulator STS-3 between the 52/155 Mb/s 75Ω DATA OUT and 52/155 Mb/s 75Ω DATA IN ports.
- 9 Press **RESULTS** **TROUBLE** **SCAN** then **RUN/STOP** to start the measurement.
- 10 Ensure that NO TROUBLE is displayed on the **RESULTS** display after 30 seconds.
- 11 Press **RUN/STOP** to stop the measurement.
- 12 Disconnect all the equipment.

## **SDH/SONET Receiver Monitor Levels**

### **Specifications**

<b>Bit Rate</b>	<b>Nominal Loss</b>	<b>Equalization at 1/2 Bit Rate</b>
STM-0/STS-1 - 51.84 Mb/s	20, 26dB	12dB
STM-1/STS-3 - 155.52 Mb/s	20, 26dB	12dB

### **Description**

The signal from the HP 37718A/19A SDH/SONET Transmitter is applied to the SDH/SONET Receiver after attenuating by an amount equal to the selected Receiver Flat Loss plus the specified Cable Loss. The Flat Loss is obtained from a 75 $\Omega$  attenuator kit. The Cable Loss is supplied by inserting the correct Cable Simulators for each bit rate in the attenuation path.

### **Equipment Required**

**Cable Simulator STM-0/STS-1** 50 metres of 8120-0049

**Cable Simulator STM-1/STS-3** 75 metres of 8120-0049

**75 $\Omega$  Attenuator Kit** HP 86213A

### **Procedure**

- 1 Recall the HP 37718A/19A DEFAULT SETTINGS as shown on page 3-4.
- 2 Connect the equipment as shown in Figure 3-5.

Performance Tests  
**SDH/SONET Receiver Monitor Levels**

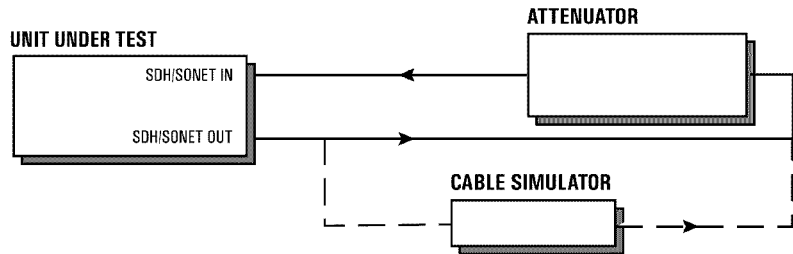

**Figure 3-5** Receiver Monitor Input Test Setup

**STM-0/STS-1**

- 1 Set the **OTHER** **SETTINGS** **CONTROL** display as shown below.

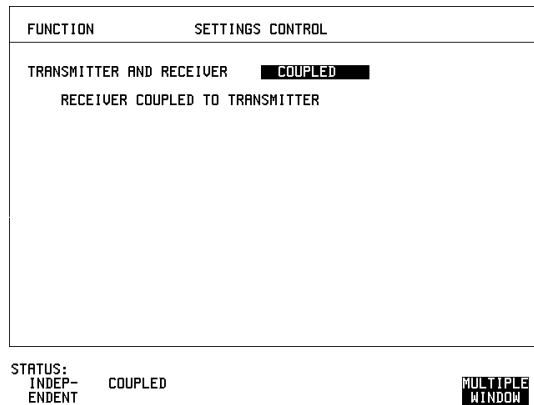

- 2 Press **RECEIVE** and set up the **MAIN** **SETTINGS** display as shown on next page.

Performance Tests  
**SDH/SONET Receiver Monitor Levels**

RECEIVER INPUT		SDH	
MAIN SETTINGS	STRUCT'D PAYLOAD	TEST FUNCTION	OVERHEAD MONITOR
SIGNAL LEVEL GAIN		STM-0 MONITOR 20 dB	
MAPPING <input type="checkbox"/>	AU-3	UC-3 34 Mb/s	
PAYLOAD TYPE	UNFRAMED	UNSTRUCTURED	
PATTERN	2 <sup>23</sup> -1 PRBS	INVERT	ITU

STATUS:  
 20 dB      26 dB      **MULTIPLE WINDOW**

- 3 Press **RESULTS** **TROUBLE SCAN**
- 4 Press **RUN/STOP** to start the measurement.
- 5 After 30 seconds ensure that NO TROUBLE is displayed on the **RESULTS** display
- 6 Press **RUN/STOP** to stop the measurement.
- 7 Connect Cable Simulator STS-1 between the 52/155 Mb/s DATA OUT Port and the attenuator.
- 8 Press **RESULTS** **TROUBLE SCAN** then **RUN/STOP** to start the measurement.
- 9 Ensure that NO TROUBLE is displayed on the **RESULTS** display after 30 seconds.
- 10 Press **RUN/STOP** to stop the measurement.
- 11 Connect the 6dB Fixed Attenuator in the signal path to give a total path attenuation of 26dB.
- 12 Press **RECEIVE** and select MONITOR LEVEL [26dB].
- 13 Press **RESULTS**; **TROUBLE SCAN** then **RUN/STOP** to start the measurement.
- 14 Ensure that NO TROUBLE is displayed on the **RESULTS** display after 30 seconds.
- 15 Press **RUN/STOP** to stop the measurement.



Performance Tests

**SDH/SONET Receiver Monitor Levels**

- 16 Remove Cable Simulator STS-1 from the signal path.
- 17 Press **RESULTS**; **TROUBLE SCAN** then **RUN/STOP** to start the measurement.
- 18 Ensure that NO TROUBLE is displayed on the **RESULTS** display after 30 seconds.
- 19 Press **RUN/STOP** to stop the measurement.

**STM-1/STS-3**

- 20 Repeat steps 1 to 19 (20dB and 26dB tests) with the **RECEIVE** display set to SIGNAL [STM-1/STS-3] and Cable Simulator STS-3 fitted in place of Cable Simulator STS-1.
- 21 Disconnect all the equipment.

---

## Multirate Optical Interfaces

### Specification (1310 nm Transmitter)

<b>Wavelength</b>	1280 nm to 1330 nm (Typical 1310 nm)
<b>Power Output</b>	+0.0 dBm to +3.0 dBm (Typical +1 dBm)
<b>Line Coding</b>	NRZ
<b>Safety Class</b>	Class 1, FDA 21 CFR Ch.1 1040.10 and EN 60825
<b>Data Rates</b>	51.84, 155.52, 622.08 or 2488.32 Mb/s (Nominal)

### Specification (1550 nm Transmitter)

<b>Wavelength</b>	1530 nm to 1570 nm (Typical 1550 nm)
<b>Power Output</b>	0.0 dBm to +3.0 dBm (Typical +1dBm)
<b>Line Coding</b>	NRZ
<b>Safety Class</b>	Class 1, FDA 21 CFR Ch.1 1040.10 and EN 60825
<b>Data Rates</b>	51.84, 155.52, 622.08 or 2488.32 Mb/s (Nominal)

---

**NOTE**

The Transmitter Wavelengths installed are dependent on HP 37718A/  
37719A option.

---

### Specification (Receiver)

<b>Wavelength</b>	1200 nm to 1600 nm
<b>Maximum Input Power</b>	-8 dBm (for BER of $1.0E^{-10}$ )
<b>Line Coding</b>	NRZ
<b>Sensitivity</b>	-34 dBm (STM-0/1/4, OC-1/3/12) -28 dBm Minimum (STM-16, OC-48) (wavelength=1310/1550 nm, Modulation = 100%, Data= $2^{23}-1$ , BER= $1.0E^{-10}$ )
<b>PMP Electrical Input</b>	150mV pk-pk (Nominal) 51.84, 155.52 and 622.08 Mb/s only
<b>PMP Impedance</b>	Nominal $50\Omega$

## **Description**

The optical power output is measured on a power meter.

The receiver sensitivity is verified by attenuating the transmitter output and checking for no errors in back-to-back mode.

The Protected Monitor Point (PMP) functionality is verified by looping the HP 37718A/19A Optical Output to the PMP input via an Optical Attenuator and Lightwave Converter, then checking for error-free operation.

## **Equipment Required**

<b>Power Meter</b>	: HP 8153A
<b>Power Meter Sensor Module</b>	: HP 81536A
<b>Oscilloscope</b>	: HP 54520A
<b>Lightwave Converter</b>	: HP 11982A
<b>Optical Attenuator</b>	: HP 8157A
<b>FC/PC Connector Interface</b>	: HP 81000FI (Qty. 4)
<b>Optical Cables (qty 2)</b>	: HP 11871A
<b>Adaptor (SMA to BNC)</b>	: HP 1250-1787

---

### **WARNING**

**Safety precautions must be observed when handling the HP 37718A/19A Optical Modules as these generate laser signals which can cause serious injury. The guidelines below must be followed: Check the connector configuration of the Fiber Optic Interfaces. If these are fitted with a connector interface other than FC/PC then remove the existing connector interface and fit the FC/PC connector interface.**

**Check for any damage to the HP 37718A/19A Fiber Optic Interface spring loaded aperture covers and connectors. Do not power up the instrument if in any doubt about the integrity of these connectors.**

**Make all connections to the HP 37718A/19A Fiber Optic Interfaces before powering up the instrument.**

---

Performance Tests  
**Multirate Optical Interfaces**

**Procedure 1310nm - Optical Power Output**

- 1 Switch on the HP 37718A/19A and recall the DEFAULT SETTINGS as shown on page 3-4.
- 2 Connect the HP 37718A/19A Optical Out Port to the HP8153A (ensure that all connections are tight and that the cable has no twists).
- 3 Setup the HP 8153A as follows:
  - a. Press **PARAM** key to display wavelength [ $\lambda$ ]
  - b. Using **←**, **→**, **↑** and **↓** keys, set the wavelength to 1310nm.
  - c. Press **PARAM** key to display Time [t]
  - d. Using **←**, **→**, **↑** and **↓** keys, set the time to 200mS.
  - e. Press **PARAM** key to display REF.
  - f. Using **←**, **→**, **↑** and **↓** keys, set the REF to 0.000dBm.
  - g. Press **PARAM** key to display CAL.
  - h. Using **←**, **→**, **↑** and **↓** keys, set the CAL to 0.000dBm.
  - i. Press the **ZERO** key on the Power Meter to calibrate - the Power Meter is now ready.
- 4 Press **MODE** to select the Power Level measurement on the HP8153A.
- 5 Press **TRANSMIT** **SDH** or **SONET** and select SIGNAL [STM-0 OPT] or [OC-1].
- 6 Check the HP8153A Power Meter reading is between 0 dBm and +3 dBm (Typically +1 dBm).
- 7 Press **TRANSMIT** **SDH** or **SONET** and select SIGNAL [STM-1 OPT] or [OC-3].
- 8 Check the HP8153A Power Meter reading is between 0 dBm and +3 dBm (Typically +1 dBm).
- 9 Press **TRANSMIT** **SDH** or **SONET** and select SIGNAL [STM-4 OPT] or [OC-12].
- 10 Check the HP8153A Power Meter reading is between 0 dBm and +3 dBm (Typically +1 dBm).
- 11 Press **TRANSMIT** **SDH** or **SONET** and select SIGNAL [STM-16 OPT] or [OC-48].
- 12 Check the HP8153A Power Meter reading is between 0 dBm and +3 dBm (Typically +1 dBm).

Performance Tests  
**Multirate Optical Interfaces**

**Optical Receiver Sensitivity**

- 13 Recall the HP 37718A/19A DEFAULT SETTINGS as shown on page 3-4.
- 14 Set the Optical Attenuator to ATTEN 15 dB, WAVELENGTH 1310 nm ; CAL=0 ; ENB ON. Connect the Optical Attenuator between the Power Meter and the HP 37718A/19A Optical Out port (ensure that all connections are tight and that the cable has no twists).
- 15 Press **TRANSMIT** **SDH** or **SONET** and select SIGNAL [STM-0 OPT] or [OC-1].
- 16 Adjust the Optical Attenuator to obtain a reading of -34 dBm on the Power Meter.
- 17 Recall the HP 37718A/19A DEFAULT SETTINGS as shown on page 3-4.
- 18 Disconnect the Optical Attenuator Output from the HP 8153A and connect to the HP 37718A/19A Optical IN Port.
- 19 Press **OTHER** then **SETTINGS CONTROL** and select TRANSMITTER AND RECEIVER [COUPLED].
- 20 Press **TRANSMIT** **SDH** or **SONET** and select SIGNAL [STM-0 OPT] or [OC-1].
- 21 Press **RESULTS** **TROUBLE SCAN** then **RUN/STOP** to start a measurement.
- 22 After 5 minutes check that NO TROUBLE is displayed on the **RESULTS** display.
- 23 Repeat steps 13 through 22, substituting SIGNAL [STM-1 OPT] or [OC-3] in steps 15 & 20.
- 24 Repeat steps 13 through 22, substituting SIGNAL [STM-4 OPT] or [OC-12] in steps 15 & 20.
- 25 Repeat steps 13 through 22, substituting SIGNAL [STM-16 OPT] or [OC-48] in steps 15 & 20 and -28 dBm in step 16.

**PMP Electrical Input**

- 26 Recall the HP 37718A/19A DEFAULT SETTINGS as shown on page 3-4.
- 27 Disconnect the optical cable from the HP 37718A/19A Optical IN port and connect to the HP 11982A Lightwave Converter input.

Performance Tests  
**Multirate Optical Interfaces**

- 28 Connect the output from the Lightwave Converter to the Oscilloscope using the SMA/BNC adaptor and 50Ω BNC cable.
- 29 Press **TRANSMIT** **SDH** or **SONET** and select SIGNAL [STM-0 OPT] or [OC-1].
- 30 Press **AUTOSCALE** on the Oscilloscope and adjust the Timebase and Range to obtain an STM-0/OC-1 waveform.
- 31 Measure the amplitude of the waveform using the Oscilloscope and adjust the Optical Attenuator until the amplitude is 150mV pk-pk.
- 32 Disconnect the output of the Lightwave Converter from the Oscilloscope and connect instead to the HP 37718A/19A Optical Module Monitor input.
- 33 Press **RECEIVE** and set up the display as shown below.

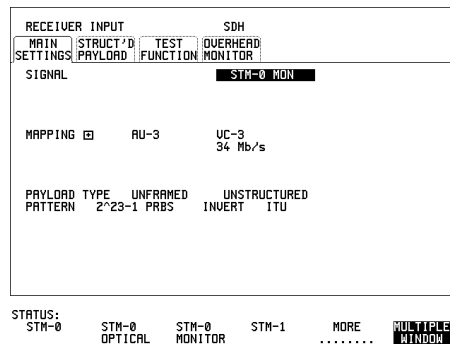

- 34 Press **RESULTS** **TROUBLE SCAN** then **RUN/STOP** to start the measurement.
- 35 After 5 minutes, check that NO TROUBLE is displayed on the **RESULTS** display. Press **RUN/STOP** to stop the measurement.
- 36 Recall the HP 37718A/19A DEFAULT SETTINGS as shown on page 3-4.
- 37 Repeat steps 28 to 36 but with [STM-1 OPT] or [OC-3] selected on the HP 37718A/19A **TRANSMIT** and **RECEIVE** displays.
- 38 Recall the HP 37718A/19A DEFAULT SETTINGS as shown on page 3-4.

Performance Tests

**Multirate Optical Interfaces**

**39** Repeat steps 28 to 36 but with [STM-4 OPT] or [OC-12] selected on the HP 37718A/19A **TRANSMIT** and **RECEIVE** displays.

**Procedure 1550 nm - Optical Power Output**

**40** Repeat steps 1 through 12 substituting 1550nm for 1310nm.

**Optical Receiver Sensitivity**

**41** Repeat Steps 13 through 25 substituting 1550nm for 1310nm.

Performance Tests  
**Multirate Optical Interfaces**



---

## **PDH Transmit/Receive Jitter Amplitude Accuracy**

### **Specifications**

Please refer to the PDH Tx/Rx Jitter Specifications given in the Specifications document provided.

### **Description**

The HP 37718A Transmitter Unbalanced PDH Output is looped to the PDH Input and the signal is also monitored on the Spectrum Analyzer. The HP 37718A Jitter modulation frequency is set to a Jitter Amplitude/Frequency check point for the selected Bit Rate and the Spectrum Analyzer set to observe the displayed spectrum centered at this bit rate. The HP 37718A jitter Modulation amplitude is adjusted to the level at which a Bessel Null is expected, then fine-tuned to null the carrier. The jitter Amplitude (UI pk-pk) displayed on the HP 37718A Transmitter and Receiver are checked to ensure they meet specified limits. The test is repeated for various Jitter Amplitude/Frequency points for each Bit Rate.

### **Equipment Required**

<b>Spectrum Analyzer</b>	: HP 8560E
<b>Oscilloscope</b>	: HP 54520A
<b>75<math>\Omega</math>/50<math>\Omega</math> Matching Pad</b>	: HP 11825B
<b>75<math>\Omega</math> Power Splitter</b>	: SUHNER 4901.02A
<b>Synthesizer</b>	: HP 3335B Opt 001
<b>75<math>\Omega</math> Termination</b>	: HP 15522-80010
<b>Blocking Capacitor</b>	: HP 10240B

Performance Tests  
**PDH Transmit/Receive Jitter Amplitude Accuracy**

**Procedure**

- 1 Connect up the equipment as shown in Figure 3-6.

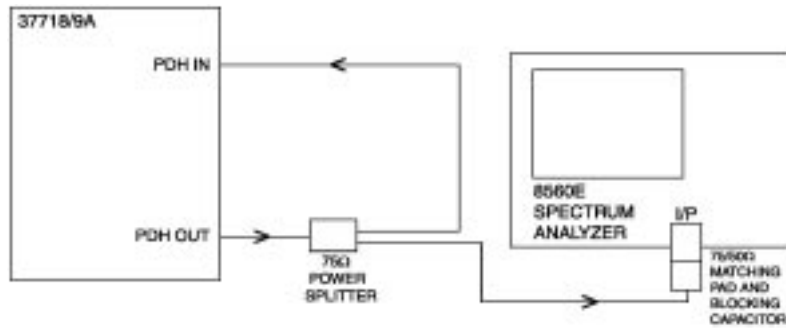

**Figure 3-6 PDH Tx/Rx Jitter Test Setup**

- 2 Recall the HP 37718A DEFAULT SETTINGS as shown on page 3-4.
- 3 Setup the HP 37718A **OTHER** display as shown opposite.

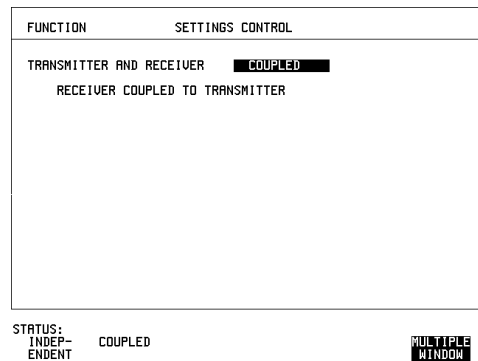

Performance Tests

**PDH Transmit/Receive Jitter Amplitude Accuracy**

**Transmit/Receive Jitter Amplitude Accuracy, Ranges (1/1.6 UIp-p)**

- 4 Setup the HP 37718A  
**TRANSMIT** display as shown opposite.

TRANSMITTER OUTPUT		PDH
MAIN SETTINGS	STRUCT'D SETTINGS	JITTER TEST FUNCTION
SIGNAL		2 Mb/s
CLOCK SYNC	INTERNAL	
TERMINATION		75Ω UNBAL
LINE CODE		HDB3
FREQUENCY OFFSET		OFF
PAYLOAD TYPE	UNFRAMED	UNSTRUCTURED
PATTERN		ALL ONES

STATUS:

MULTIPLE WINDOW

- 5 Select TRANSMITTER OUTPUT SETTINGS [JITTER] and setup the display as shown opposite.

TRANSMITTER OUTPUT		PDH
MAIN SETTINGS	STRUCT'D SETTINGS	JITTER TEST FUNCTION
JITTER / WANDER		JITTER
JITTER		ON
SIGNAL FREQUENCY		2 Mb/s
MODULATION SOURCE		INTERNAL
JITTER MASK		OFF
CLOCK SYNC		INTERNAL
RANGE	<input checked="" type="checkbox"/>	1.0 UI
MODULATION FREQUENCY	<input checked="" type="checkbox"/>	2400 Hz
AMPLITUDE	<input checked="" type="checkbox"/>	0.77 UI

STATUS:

MULTIPLE WINDOW

- 6 Select RECEIVER INPUT SETTINGS [JITTER] and setup as shown below.

RECEIVER INPUT		PDH/DSn
MAIN SETTINGS	STRUCT'D SETTINGS	JITTER TEST FUNCTION
MEASUREMENT TYPE		JITTER
SIGNAL FREQUENCY		2 Mb/s
RECEIVER RANGE		1.6 UI
HIT THRESHOLD		1.60 UI
FILTER		HP1

STATUS:

MULTIPLE WINDOW

## Performance Tests

### PDH Transmit/Receive Jitter Amplitude Accuracy

- 7 Select **RESULTS** and set for PDH Jitter, Short Term. Set to Multiple Window to allow observation of TX/RX Jitter and Results pages.

TRANSMITTER OUTPUT PDH MAIN STRUCTURE JITTER TEST SETTINGS SETTINGS) FUNCTION)		RECEIVER INPUT PDH MAIN STRUCTURE JITTER SETTINGS SETTINGS)	
JITTER / WANDER JITTER JITTER ON SIGNAL FREQUENCY 2.1M/s MODULATION SOURCE INTERNAL JITTER PEAK OFF CLOCK SYNC INTERNAL		MEASUREMENT TYPE JITTER SIGNAL FREQUENCY 2.1M/s RECEIVER RANGE 1.5 UI HIT THRESHOLD 1.00 UI FILTER HP1	
RANGE <input type="checkbox"/> 1.0 UI MODULATION FREQUENCY <input type="checkbox"/> 2400 Hz AMPLITUDE <input type="checkbox"/> 0.77 UI			
RESULTS JITTER SHORT TERM		FUNCTION SETTINGS CONTROL	
+VE PEAK 0.377UI -VE PEAK 0.378UI PEAK-PEAK 0.755UI RMS 0.268UI FILTERS HP1 ELAPSED TIME 00d 00h 03m 32s		TRANSMITTER AND RECEIVER COUPLED RECEIVER COUPLED TO TRANSMITTER	
STATUS: CUMULATIVE		SHORT TERM	AUTO TOLER
		TRANSFER FUNCTION	<b>SINGLE WINDOW</b>

- 8 Check the Receiver AIS Led is on.
- 9 Set the Spectrum Analyzer as follows:  
 Centre Frequency - 2048 kHz (set to bit rate being checked)  
 Frequency Span - 25 kHz (approx 10 times the jitter modulation frequency)  
 Reference Level - 0 dBm  
 Sweep Time - Auto  
 Video Bandwidth - Auto  
 Resolution Bandwidth - Auto

## Performance Tests

### PDH Transmit/Receive Jitter Amplitude Accuracy

#### TX/RX Jitter Accuracy Test Setup, Ranges (1/1.6 UIp-p)

- Adjust the HP 37718A jitter amplitude until the first **Bessel Null** is observed on the Spectrum Analyzer i.e first dip in the carrier level (see Figure 3-7).

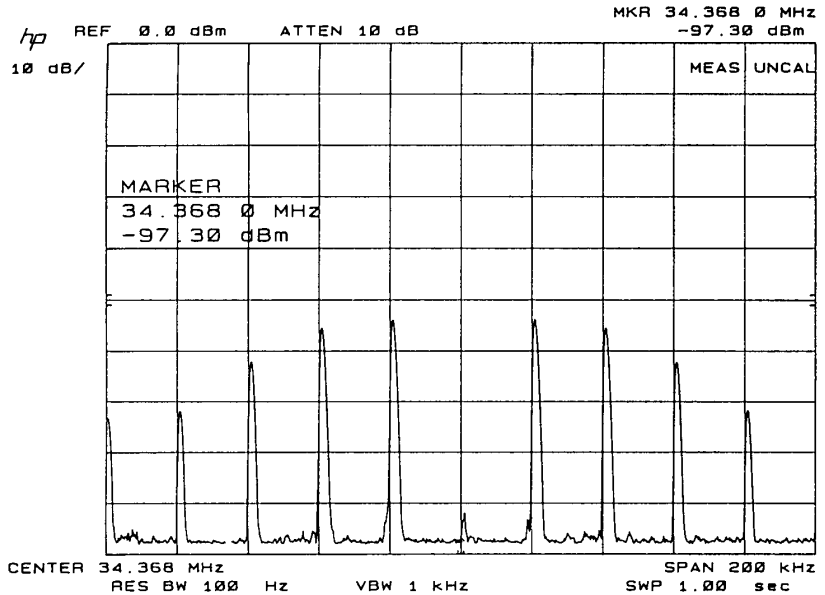

Figure 3-7

#### Bessel Null Example

#### NOTE

Set the Spectrum Analyzer centre frequency to the bit rate being tested.

- Press RUN to start the measurement.
- Ensure the Jitter amplitude displayed on the HP 37718A Transmit and Receive displays are between the minimum and maximum limits given in Table 3-4.

Performance Tests  
**PDH Transmit/Receive Jitter Amplitude Accuracy**

**Table 3-4 Tx/Rx Jitter Amplitude Accuracy, Ranges (1/1.6 Ulp-p)**

Bit Rate/ Center Frequency	Modulation Frequency	Null Jitter Amplitude (UI)	Minimum Jitter (UI) TX	Maximum Jitter (UI) TX	Minimum Jitter (UI) RX	Maximum Jitter (UI) RX
2048kHz	2400Hz	0.77	0.69	0.83	0.711	0.829
8448kHz	10700Hz	0.77	0.69	0.83	0.706	0.834
34368kHz	4000Hz	0.77	0.69	0.83	0.706	0.834
139264kHz	4000Hz	0.77	0.68	0.84	0.706	0.834

**NOTE** The Bit Rates available are dependent on the HP 37718A option.

- 13** Press STOP to stop measurement.
- 14** Check the Jitter accuracy for each value in Table 3-4. In each case, set the HP 37718A Rate and Spectrum Analyzer Center Frequency to the value given in column 1 of the table (**Set the HP 37718A PATTERN to ALL ONES and JITTER AMPLITUDE to minimum after each change of Bit Rate**). Set the HP 37718A Jitter Modulation Frequency and Amplitude to the values given in columns 2 and 3 of the table. Fine-tune the amplitude to obtain the lowest carrier level on the Spectrum Analyzer display and check that the jitter amplitude displayed on the HP 37718A TX settings & RX results are between the limits given in columns 4 to 7 of Table 3-4.

## Performance Tests

### PDH Transmit/Receive Jitter Amplitude Accuracy

#### Transmit/Receive Jitter Amplitude Accuracy, Ranges (10/16 UIp-p)

15 Setup the HP 37718A

**TRANSMIT** display as shown opposite.

TRANSMITTER OUTPUT		PDH
MAIN SETTINGS	STRUCT'D SETTINGS	TEST FUNCTION
SIGNAL		2 Mb/s
CLOCK SYNC	INTERNAL	
TERMINATION		75Ω UNBAL
LINE CODE		HDB3
FREQUENCY OFFSET		OFF
PAYLOAD TYPE	UNFRAMED	UNSTRUCTURED
PATTERN		ALL ONES

STATUS:

**MULTIPLE WINDOW**

16 Select **TRANSMIT JITTER** and setup the display as shown opposite.

TRANSMITTER OUTPUT		PDH/DS <sub>n</sub>
MAIN SETTINGS	STRUCT'D SETTINGS	TEST FUNCTION
JITTER / WANDER		JITTER
JITTER		ON
SIGNAL FREQUENCY		2 Mb/s
MODULATION SOURCE		INTERNAL
JITTER MASK		OFF
CLOCK SYNC		INTERNAL
RANGE		10 UI
MODULATION FREQUENCY		2400 Hz
AMPLITUDE		1.8 UI

STATUS:

**MULTIPLE WINDOW**

17 Select RECEIVER INPUT SETTINGS [JITTER] and setup the display as shown opposite.

RECEIVER INPUT		PDH
MAIN SETTINGS	STRUCT'D SETTINGS	JITTER
MEASUREMENT TYPE		JITTER
SIGNAL FREQUENCY		2 Mb/s
RECEIVER RANGE		16 UI
HIT THRESHOLD		1.0 UI
FILTER		HP1

STATUS:

**MULTIPLE WINDOW**

## Performance Tests

### PDH Transmit/Receive Jitter Amplitude Accuracy

- 18 Select **RESULTS** and set for PDH Jitter, Short Term. (Timing Control, 1 Second, Manual). Set to Multiple Window to allow observation of TX/RX Jitter and Results pages.

TRANSMITTER OUTPUT		PDH		RECEIVER INPUT		PDH	
MAIN	STRUCT'D	JITTER	TEST	MAIN	STRUCT'D	JITTER	TEST
SETTINGS/SETTINGS		FUNCTION		SETTINGS/SETTINGS		FUNCTION	
JITTER / WANDER	JITTER	JITTER	JITTER	MEASUREMENT TYPE	JITTER	JITTER	JITTER
JITTER	ON	ON	ON	SIGNAL FREQUENCY	2 Hz/s	2 Hz/s	2 Hz/s
SIGNAL FREQUENCY	2 Hz/s	INTERNAL	INTERNAL	RECEIVER RANGE	10 UI	10 UI	10 UI
MODULATION SOURCE	INTERNAL	OFF	OFF	HIT THRESHOLD	1.0 UI	1.0 UI	1.0 UI
JITTER MASK	OFF	INTERNAL	INTERNAL	FILTER	HP1	HP1	HP1
CLOCK SYNC	INTERNAL	INTERNAL	INTERNAL				
RANGE	10 UI	10 UI	10 UI				
MODULATION FREQUENCY	2400 Hz	2400 Hz	2400 Hz				
AMPLITUDE	1.8 UI	1.8 UI	1.8 UI				

RESULTS		JITTER		SHORT TERM		FUNCTION		SETTINGS CONTROL	
+VE PEAK	0.710UI	0.710UI	0.710UI	TRANSMITTER AND RECEIVER	COUPLED	COUPLED	COUPLED	COUPLED	COUPLED
-VE PEAK	0.765UI	0.765UI	0.765UI	RECEIVER COUPLED TO TRANSMITTER	RECEIVER COUPLED TO TRANSMITTER	RECEIVER COUPLED TO TRANSMITTER	RECEIVER COUPLED TO TRANSMITTER	RECEIVER COUPLED TO TRANSMITTER	RECEIVER COUPLED TO TRANSMITTER
PEAK-PEAK	1.475UI	1.475UI	1.475UI						
RMS	0.551UI	0.551UI	0.551UI						
FILTERS	HP1	HP1	HP1						
ELAPSED TIME	00d 00m 09s 31s	00d 00m 09s 31s	00d 00m 09s 31s						

STATUS:	CUMUL	SHORT	AUTO	TRANSFER	SINGLE
	ACTIVE	TERM	TOLER	FUNCTION	WINDOW

- 19 Check the Receiver AIS Led is on.

- 20 Set the Spectrum Analyzer as follows:

Centre Frequency - 2048 kHz

Frequency Span - 25 kHz

Reference Level - 0 dBm

Sweep Time - 1.0 s

Video Bandwidth - 1 kHz

Resolution Bandwidth - 100Hz

- 21 Adjust the HP 37718A jitter amplitude until the second **Bessel Null** is observed on the Spectrum Analyzer i.e second dip in the carrier level.
- 22 Ensure the Jitter amplitude displayed on the HP 37718A **TX** display is between the minimum and maximum limits given in Table 3-5.

#### NOTE

To optimize **Bessel Null** to check the Receiver Accuracy it is necessary to use an external modulation source to give better amplitude resolution. The HP 37718A is set to accept External modulation source and the synthesizer is set to the same jitter frequency as used for Internal modulation and the level is fine adjusted to optimize the null point being checked.

- 23 Set the TX MODULATION SOURCE to EXTERNAL. Set the synthesizer to the jitter frequency being tested and set the level to achieve the null being tested.



Performance Tests

**PDH Transmit/Receive Jitter Amplitude Accuracy**

Check the Received Jitter Accuracy is within the limits in Table 3-5.

**24** Return the TX MODULATION SOURCE to INTERNAL.

**25** Check the Jitter accuracy for each value in Table 3-5. In each case, set the HP 37718A Rate and Spectrum Analyzer Center Frequency to the value given in column 1 of the table (**Set the HP 37718A PATTERN to ALL ONES and the JITTER AMPLITUDE to minimum after each change of Bit Rate**). Set the HP 37718A Jitter Modulation Frequency and Amplitude to the values given in columns 2 and 3 of the table. Fine-tune the amplitude to obtain the lowest carrier level on the Spectrum Analyzer display and check that the **TX** jitter amplitude displayed on the HP 37718A is between the limits given in columns 4 and 5 of Table 3-5.

**Table 3-5 Range 10/16 Tx/Rx Jitter Amplitude Accuracy**

Bit Rate/ Center Frequency	Modulation Frequency	Nullled Jitter Amplitude (UI)	Minimum Jitter (UI) TX	Maximum Jitter (UI) TX	Minimum Jitter (UI) RX	Maximum Jitter (UI) RX
2048kHz	2400Hz	1.8	1.5	2.0	1.587	1.933
2048kHz	2400Hz	4.8	4.4	5.1	4.377	5.143
2048kHz	2400Hz	8.8	8.2	9.3	8.097	9.423
8448kHz	10700Hz	1.8	1.5	2.0	1.587	1.933
8448kHz	10700Hz	5.8	5.3	6.2	5.307	6.213
8448kHz	10700Hz	8.8	8.2	9.3	8.097	9.423
34368kHz	4000Hz	2.8	2.5	3.0	2.517	3.003
34368kHz	4000Hz	6.8	6.2	7.3	6.237	7.283
34368kHz	4000Hz	8.8	8.2	9.3	8.097	9.423
139264kHz	4000Hz	3.8	3.3	4.2	3.447	4.073
139264kHz	4000Hz	7.8	7.1	8.4	7.167	8.353
139264kHz	4000Hz	8.8	8.1	9.4	8.097	9.423

Performance Tests  
**PDH Transmit/Receive Jitter Amplitude Accuracy**

**NOTE**

The Bit Rates available are dependent on the HP 37718A option.

**External Jitter Generation and Demod Output**

- 1 Add the Synthesizer and oscilloscope to the set-up as shown below.

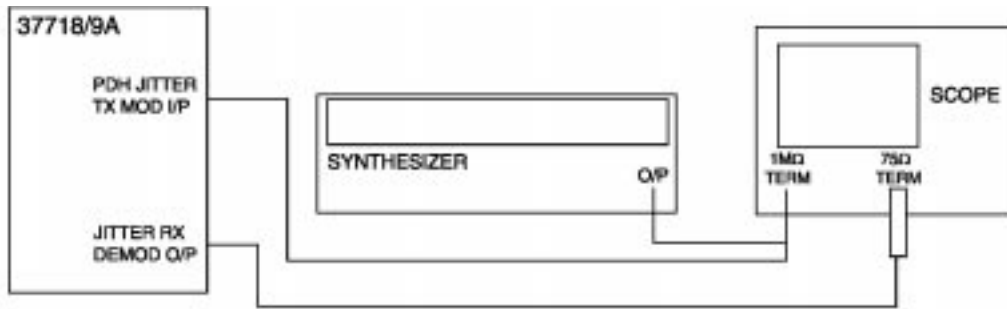

**Figure 3-8 PDH External Jitter Generation and Demod Output Test Setup**

- 2 Setup the HP 37718A  
 **TRANSMIT** display as shown opposite.

TRANSMITTER OUTPUT		PDH
MAIN	STRUCT'D	JITTER
SETTINGS	SETTINGS	TEST
		FUNCTION
SIGNAL		2 Mb/s
CLOCK	SYNC	INTERNAL
TERMINATION		75Ω UNBAL
LINE CODE		HDB3
FREQUENCY	OFFSET	OFF
PAYLOAD TYPE	UNFRAMED	UNSTRUCTURED
PATTERN		ALL ONES

STATUS:

**MULTIPLE WINDOW**

## Performance Tests

### PDH Transmit/Receive Jitter Amplitude Accuracy

- 3 Select TRANSMITTER OUTPUT SETTINGS [JITTER] and setup the display as shown opposite.

TRANSMITTER OUTPUT		PDH
MAIN	STRUCT'D	TEST
SETTINGS	SETTINGS	FUNCTION
JITTER / WANDER	JITTER	ON
JITTER		ON
SIGNAL FREQUENCY		2 Mb/s
MODULATION SOURCE		EXTERNAL
RANGE		<input type="checkbox"/> 2 UI
CLOCK SYNC		INTERNAL
SELECT AN EXTERNAL CLOCK SYNC WHEN		
MODULATION FREQUENCY IS BELOW 2Hz		

STATUS:

MULTIPLE  
WINDOW

- 4 Select RECEIVER INPUT SETTINGS [JITTER] and setup as shown below:

RECEIVER INPUT		PDH/DSn
MAIN	STRUCT'D	TEST
SETTINGS	SETTINGS	FUNCTION
MEASUREMENT TYPE	JITTER	JITTER
SIGNAL FREQUENCY		2 Mb/s
RECEIVER RANGE		1.6 UI
HIT THRESHOLD		1.60 UI
FILTER		HP1

STATUS:

MULTIPLE  
WINDOW

- 5 Set the Spectrum Analyzer as follows:
  - Centre Frequency - 2048 kHz (set to bit rate being checked)
  - Frequency Span - 25 kHz (approx 10 times the jitter modulation frequency)
  - Reference Level - 0 dBm
  - Sweep Time - Auto
  - Video Bandwidth - Auto
  - Resolution Bandwidth - Auto
- 6 Set the Synthesizer to Frequency 10 kHz and minimum Output level.
- 7 Increase the Synthesizer output level until the first **Bessel Null** is observed on the Spectrum Analyzer.

## Performance Tests

### **PDH Transmit/Receive Jitter Amplitude Accuracy**

- 8** Check that the Synthesizer amplitude waveform on the Oscilloscope is between 1.76V pk\_pk and 2.84V pk\_pk.
- 9** Check that the HP 37718A Demod Output amplitude waveform on the Oscilloscope is between 707 and 833mV pk\_pk.

---

## **SDH Transmit/Receive Jitter Amplitude Accuracy**

### **Specifications**

Please refer to the SDH Tx/Rx Jitter Specifications given in the Specifications document provided.

### **Description**

The HP 37718A Transmitter SDH Output is looped to the SDH Input and the signal is also monitored on the Spectrum Analyzer. The HP 37718A Jitter modulation frequency is set to a Jitter Amplitude/Frequency check point for the selected SDH Rate and the Spectrum Analyzer set to observe the displayed spectrum centered at half this bit rate. The HP 37718A jitter Modulation amplitude is adjusted to known modulation levels using **Carrier to Sideband Ratio**, **Bessel Null** and **Peak Deviation** methods for reference. The jitter Amplitude (UI pk-pk) displayed on the HP 37718A Transmitter and Receiver is checked to ensure it is within specified limits. The test is repeated for various Jitter Amplitude/Frequency points to check the TX and RX ranges.

The Optical SDH rates are tested in a similar way. In this case the HP 37718A Optical Transmit signal is split using an optical coupler. Part is looped back via an Optical Attenuator to the HP 37718A Receiver. The split signal is passed through an O/E Converter to provide an electrical version of the signal for Spectrum Analysis.

Because the SDH Data signal is scrambled this is switched off to observe the spectral components at half bit rate. A special Calibration test signal is selected which sets the output pattern to alternating 1/0.

---

### **WARNING**

**Safety precautions must be observed when handling the HP 37718A Optical Modules as these generate laser signals which can cause injury. The guidelines below must be followed:**

**Check the connector configuration of the Fiber Optic Interfaces. If these are fitted with a connector interface other than FC/PC then remove the existing connector interface and fit the FC/PC connector interface.**

**Check for any damage to the HP 37718A Fiber Optic Interface spring loaded aperture covers and connectors. Do not power up the instrument if in any doubt about the integrity of these connectors.**

Performance Tests  
**SDH Transmit/Receive Jitter Amplitude Accuracy**

## Equipment Required

<b>Spectrum Analyzer</b>	: HP 8560E
<b>Optical Coupler</b>	: HP 15744C
<b>O/E Converter</b>	: HP 11982A
<b>Optical Attenuator</b>	: HP 8156A*
<b>Synthesizer</b>	: HP 3335B Opt 001
<b>Oscilloscope</b>	: HP 54520A
<b>75Ω/50Ω Matching Pad</b>	: HP 11825B
<b>75Ω Power Splitter</b>	: SUHNER 4901.02A
<b>75Ω Termination</b>	: HP 15522-80010
<b>Blocking Capacitor</b>	: HP 10240B

\* Note the 15dB optical attenuator accessory E4546A (supplied with your instrument) is NOT suitable for this purpose.

- 1 Recall the HP 37718A DEFAULT SETTINGS as shown on page 3-4.
- 2 Setup the HP 37718A **OTHER** display as shown opposite.

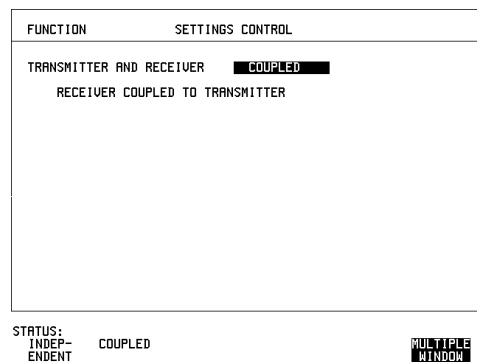

## SDH Transmit/Receive Jitter Amplitude Accuracy

### Procedure

#### STM-1e Electrical Transmit/Receive SDH Jitter Amplitude Accuracy

- 3 Connect up the equipment as shown in Figure 3-9.

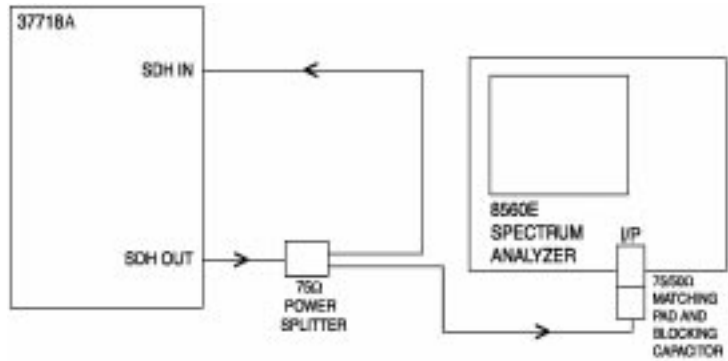

Figure 3-9

#### STM-1e Electrical Transmit/Receive Test Setup

- 4 Select **TRANSMIT** and setup the HP 37718A display as shown opposite. Setup for STM-1 E CMI with bulk loading.

TRANSMITTER OUTPUT		SDH	
MAIN SETTINGS	STRUCT'D PAYLOAD	JITTER	TEST OVERHEAD FUNCTION SETUP
SIGNAL CLOCK FREQUENCY	STM-1 INTERNAL OFFSET	OFF	INTERNAL
MAPPING	<input checked="" type="checkbox"/> AU-4		BACKGROUND UC-4 BULK FILLED
PATTERN	2 <sup>n</sup> 23-1 PRBS	INVERT	ITU

STATUS:

MULTIPLE WINDOW

Performance Tests  
**SDH Transmit/Receive Jitter Amplitude Accuracy**

- 5 Select **TRANSMIT JITTER** and ensure Jitter is set to OFF.

TRANSMITTER OUTPUT			SDH	
MAIN SETTINGS	STRUCT'D PAYLOAD	JITTER	TEST FUNCTION	OVERHEAD SETUP
JITTER / WANDER		JITTER		
JITTER		OFF		

STATUS:

**MULTIPLE WINDOW**

- 6 Select RECEIVER INPUT SETTINGS [JITTER] and setup as shown below.

RECEIVER INPUT			SDH	
MAIN SETTINGS	STRUCT'D PAYLOAD	JITTER	TEST FUNCTION	OVERHEAD MONITOR
MEASUREMENT TYPE		JITTER		
SIGNAL FREQUENCY		155Mb/s		
RECEIVER RANGE		1.6 UI		
HIT THRESHOLD		1.00 UI		
FILTER		LP+HP2		

STATUS:

**MULTIPLE WINDOW**



Performance Tests

**SDH Transmit/Receive Jitter Amplitude Accuracy**

- 7 Select **RESULTS** and set for SDH Jitter, Short Term. ( Ensure the Timing Control is set for I Sec Manual)  
Set to Multiple Window to allow observation of TX/RX Jitter and Results pages.

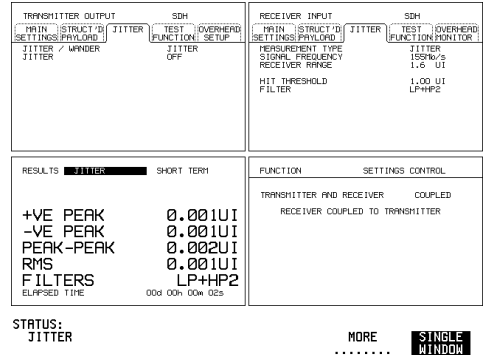

- 8 Press RUN.  
Check that there are no SDH result errors and that the Received Jitter results are: < 0.050 UI p-p
- 9 Press STOP to halt measurement. Change Receiver Filter to LP+HP1. Press RUN and check that the Received Jitter results are: < 0.050 UI p-p  
  
Press STOP to halt measurement.

- 10 Select **OTHER** display and CALIBRATION and set up PATTERN to ALT as shown opposite.  
**Note** to access CALIBRATION pages you must enter code 1243 to gain access.

Note: Do not select or run any other Calibration Items.

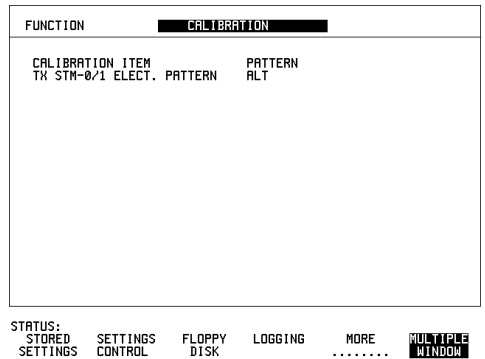

Performance Tests  
**SDH Transmit/Receive Jitter Amplitude Accuracy**

**NOTE**

The receiver will show SDH errors, (LOF/OOF, PATTERN LOSS, AU-LOP), when pattern is set to ALT as there is no Framing etc. This calibration test pattern allows spectral monitoring of the jittered signal

- 11 Select **TRANSMIT** **JITTER** and setup the display as shown opposite.

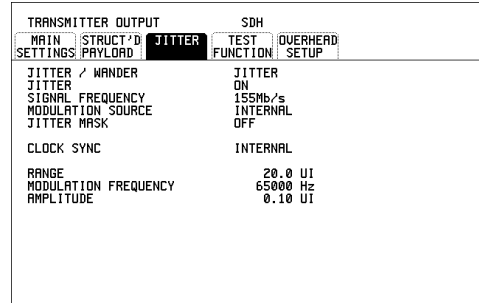

STATUS:

**MULTIPLE WINDOW**

- 12 Set the Spectrum Analyzer as follows:  
**Centre Frequency** - 77.76 MHz (half bit rate being tested)  
 e.g. 311.04 MHz for STM-4, 1.24416 GHz for STM-16.  
**Frequency Span** - 325 kHz (set to approx 5 times the Jitter frequency in step 11)  
**Reference Level** - approx -15dBm depends splitter/optical coupler & O/E converter used.  
**Sweep Time** - Auto.  
**Video Bandwidth** - Auto.  
**Resolution Bandwidth** - Auto.
- 13 Increase the Jitter Amplitude from minimum until the **Carrier to Sideband Ratio** is nearest to -22.07dB. This should be at approx 0.10 UI p-p. Use the Spectrum Analyzer dB/Div and delta marker measurement to aid measurement. Note for optical SDH rates use - 15.97db = 0.20 UI p-p.

**SDH Transmit/Receive Jitter Amplitude Accuracy**

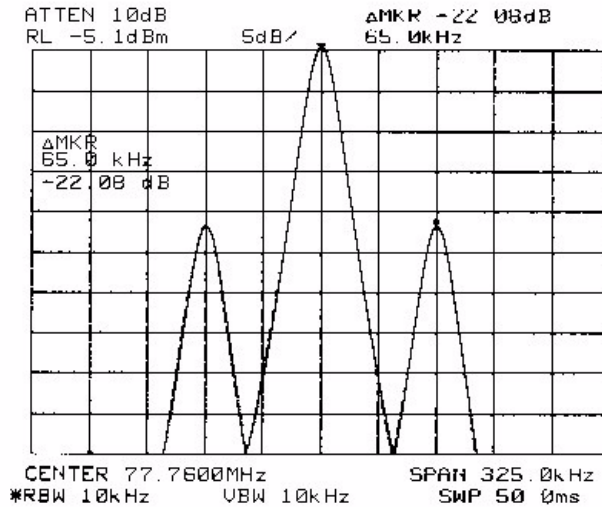

**Figure 3-10 Carrier to Sideband Ratio Example**

---

**NOTE** Compensate the measurement if necessary to balance any difference between the upper and lower sideband amplitudes.

---



---

**NOTE** To optimize amplitude for checking the Receiver Accuracy it may be necessary to use an external modulation source to give better amplitude resolution. Set the HP 37718A to accept an External modulation source and set the synthesizer to the same jitter frequency as used for Internal modulation. Adjust the level from minimum until the Carrier/Sideband amplitude is within 0.10 dB of the required difference.

---

**14** Set the Calibration Pattern to OFF. Check that there are no SDH errors.

**15** Select **RESULTS**. Press RUN to start measurement.  
 Check the TX Jitter UI p-p setting is between 0.06 and 0.14 UI p-p  
 Check the RX Jitter results are between 0.043 and 0.157 UI p-p.

---

**NOTE** If using Multiple Display window ensure RESULTS display is selected before running measurement.

---

## Performance Tests

### SDH Transmit/Receive Jitter Amplitude Accuracy

- 16 Press STOP to halt measurement. Change Receiver Filter to LP+HP2.
- 17 Set the Calibration Pattern to ALT
- 18 Change the Jitter Frequency to 650 kHz and adjust the Spectrum Analyzer span to approx 5 times the Jitter frequency. Adjust the HP37718A Transmit Jitter amplitude if necessary for a **Carrier to Sideband Ratio** of  $-22.07 \text{ dB} = 0.1 \text{ UI p-p}$  (for Optical SDH rates use  $-15.97 \text{ dB} = 0.2 \text{ UI p-p}$ )
- 19 Set the Calibration Pattern to OFF. Check that there are no SDH errors.
- 20 Select **RESULTS** . Press RUN to start measurement.  
Check the TX Jitter UI p-p setting is between 0.06 and 0.14 UI p-p  
Check the RX Jitter results are between 0.042 and 0.158 UI p-p.  
Press STOP to halt measurement.
- 21 Set the Calibration Pattern to ALT
- 22 Change the Jitter Frequency to 6.5 kHz and adjust the Spectrum Analyzer span to approx 3 times the Jitter frequency.
- 23 Adjust the HP 37718A jitter amplitude (approximately 0.91 UI) and adjust until the Carrier and first sidebands observed on the Spectrum Analyzer are the same amplitude within 0.10 dB (see Figure 3-11).

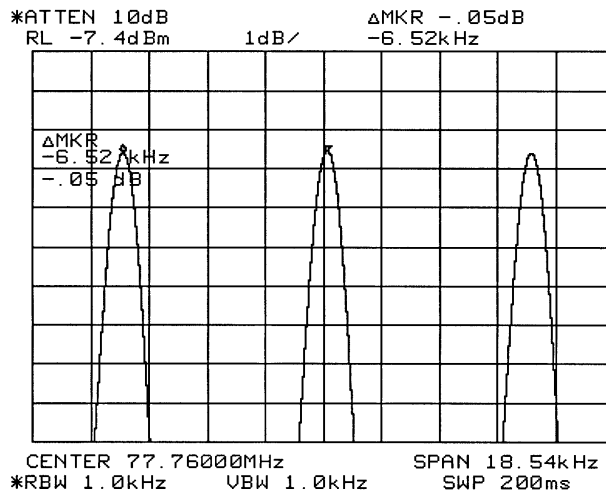

Note: Use Spectrum Analyzer dB/Div to improve Marker Resolution as necessary.

Figure 3-11

Carrier/Sideband Equal Example

## Performance Tests

### SDH Transmit/Receive Jitter Amplitude Accuracy

- 24 Set the Calibration Pattern to OFF. Check that there are no SDH errors.
- 25 Set Receiver Filter to LP+HP1. Select RESULTS. Press RUN to start measurement.  
Check the TX Jitter UI p-p setting is between 0.82 and 1.00 UI p-p  
Check the RX Jitter results are between 0.796 and 1.024 UI p-p.  
Press STOP to halt measurement.
- 26 Set the Calibration Pattern to ALT.
- 27 Change the Receiver Range to 16UI.
- 28 Change the Jitter Frequency to 4 kHz and adjust the Spectrum Analyzer span to approx 5 times the Jitter frequency.
- 29 Adjust the HP 37718A jitter amplitude (approximately 3.52 UI) until the 2nd Bessel Null is observed on the Spectrum Analyzer i.e 2nd dip in the carrier level (see Figure 3-12).

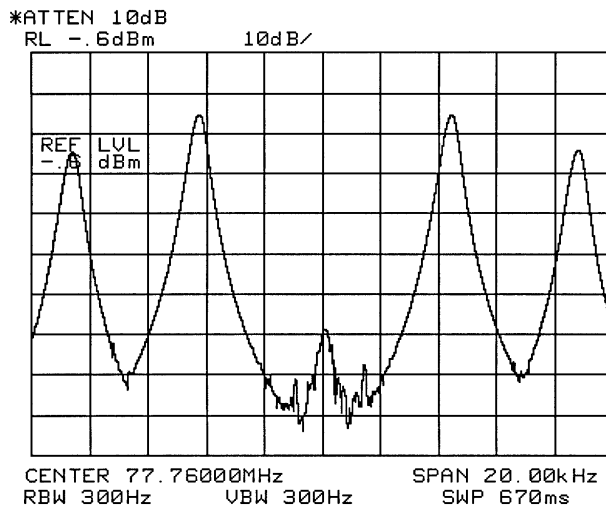

Figure 3-12

### Second Bessel Null Example

- 30 Set the Calibration Pattern to OFF. Check that there are no SDH errors.
- 31 Ensure the Receiver Filter to LP+HP1. Select **RESULTS**. Press RUN to start the measurement.  
Check the TX Jitter UI p-p setting is between 3.30 and 3.74 UI p-p  
Check the RX Jitter results are between 3.174 and 3.866 UI p-p.  
Press STOP to halt measurement.

## Performance Tests

### SDH Transmit/Receive Jitter Amplitude Accuracy

- 32 Set the Calibration Pattern to ALT
- 33 Change the Jitter Frequency to 2.5 kHz and adjust the Spectrum Analyzer span to approx 5 times the Jitter frequency.
- 34 Adjust the HP 37718A jitter amplitude (approximately 7.52 UI) until the 4th **Bessel Null** is observed on the Spectrum Analyzer i.e 4th dip in the carrier level (see Figure 3-10). For STM-4 use 11.52 UI, 6th null. For STM-16 use 9.52 UI, 5th null.
- 35 Set the Calibration Pattern to OFF. Check that there are no SDH errors.
- 36 Set the Receiver Filter to LP+HP1. Select **RESULTS** . Press RUN to start the measurement.  
Check the TX Jitter UI p-p setting is between 7.10 and 7.94 UI p-p.  
Check the RX Jitter results are between 6.756 and 8.164 UI p-p.
- 37 Press STOP to halt measurement.
- 38 Set the Calibration Pattern to ALT
- 39 Change the Transmit Jitter Range to 50UI and Receiver Measurement Type to EXTENDED.
- 40 Change the Jitter Frequency to 50Hz and Jitter Amplitude to 33UI p-p.

---

#### NOTE

Set the Spectrum Analyzer Span to approx 7 kHz and adjust Bandwidth & Sweep Time controls as necessary. Measure the peak to peak deviation of the carrier using markers. Adjust the Jitter Amplitude until the deviation at the amplitude peaks is  $4.95 \pm 0.05$  kHz.

---

---

#### NOTE

It may be necessary to use an external modulation source to give better amplitude resolution to optimise the measurement . The HP 37718A is set to accept External modulation source and the synthesizer is set to the same jitter frequency as used for Internal modulation and the level is fine adjusted to the desired frequency span.

---

Performance Tests

**SDH Transmit/Receive Jitter Amplitude Accuracy**

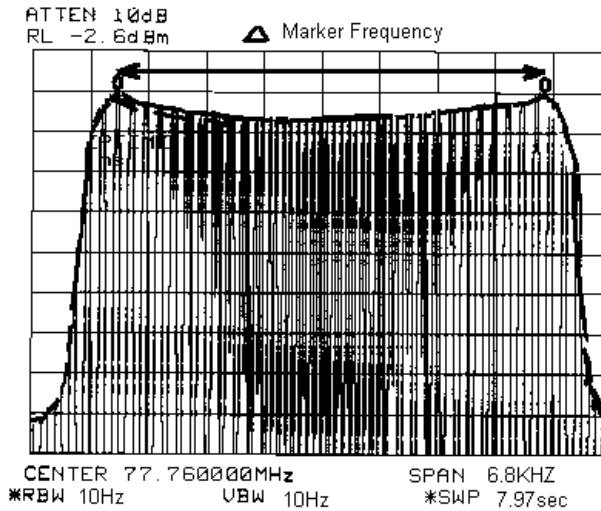

**Figure 3-13**

**Peak Deviation Example**

	Centre Freq	Span	BW	Sweep	$\Delta$ Freq kHz
For STM-4	311.04 MHz	24 kHz	10 Hz	12 seconds	20.3 $\pm$ 0.25
For STM-16	1.24416 GHz	90 kHz	10 Hz	33 seconds	82.3 $\pm$ 0.5

- 41 Set the Calibration Pattern to OFF. Check that there are no SDH errors
- 42 Select **RESULTS**. Press RUN to start measurement.  
Check the Transmit Display is between 30.82 and 35.18 UI p-p  
Check the RX Jitter results are between 28.350 and 37.650 UI p-p.  
Press STOP to halt measurement.
- 43 Set Jitter to OFF.

Performance Tests  
**SDH Transmit/Receive Jitter Amplitude Accuracy**

**Optical Transmit/Receive SDH Jitter Accuracy**

**44** Connect the equipment as shown below.

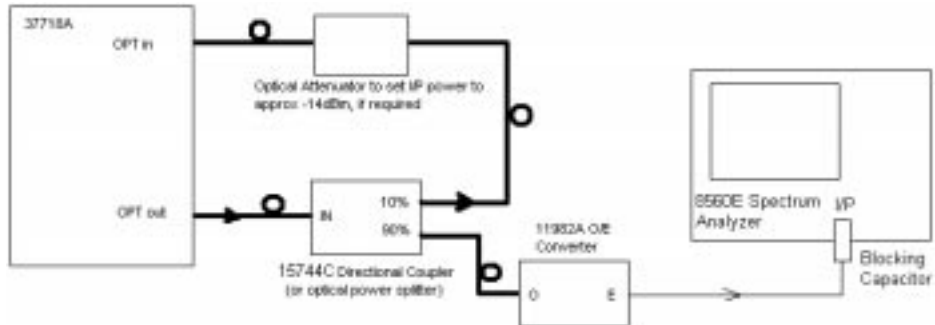

**Figure 3-14** Optical Transmit/Receive SDH Jitter Test Setup

**45** Setup the HP 37718A **TRANSMIT** display as shown below.

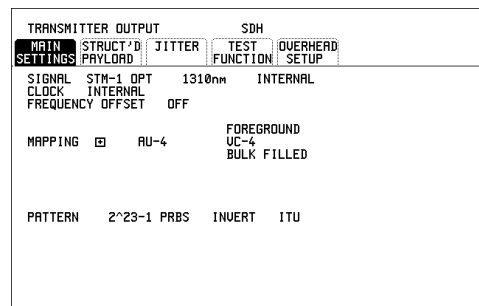

STATUS:

**MULTIPLE WINDOW**

**NOTE** Use the available wavelength 1310/1550nm. Where both are fitted select 1310nm.



## Performance Tests

### SDH Transmit/Receive Jitter Amplitude Accuracy

- 46 Select **TRANSMIT JITTER** and ensure Jitter is set to OFF and Calibration Pattern is set to OFF.

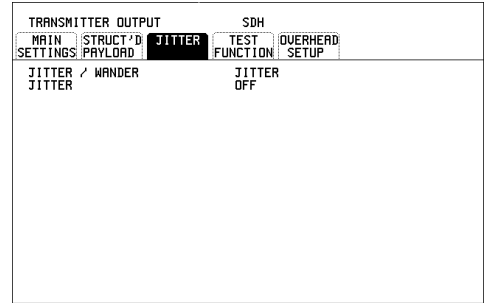

STATUS:

MULTIPLE WINDOW

- 47 Check the Optical Power measurement Results and adjust the Optical Attenuation as necessary for Received optical power within the BER & JITTER range. Record the Optical power reading.

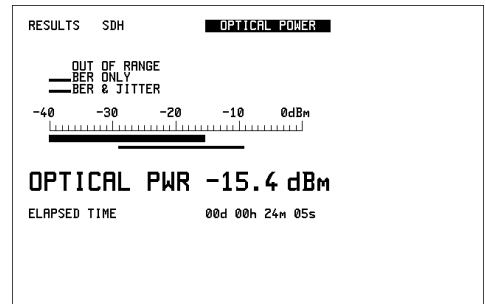

STATUS:  
OPTICAL  
POWER

MORE ..... MULTIPLE WINDOW

Performance Tests

**SDH Transmit/Receive Jitter Amplitude Accuracy**

**STM-1 Optical**

**48** Repeat steps 6 to 43 using the information in the Table below for STM-1 Optical Rate.

STEP	Tx Range	RX Range	RX Filter	Tx UI p-p	Tx Freq	TX Result MIN p-p	TX Result MAX p-p	RX Result MIN p-p	RX Result MAX p-p					
6-8	OFF	1.6UI	LP+HP2	OFF	OFF	OFF	OFF	N/A	0.050					
9	OFF	1.6UI	LP+HP1	OFF	OFF	OFF	OFF	N/A	0.050					
13-15	20	1.6UI	LP+HP1	0.2	65 kHz	0.15	0.25	0.136	0.264					
16-20			LP+HP2		650 kHz									
22-25			LP+HP1		0.91					6.5K	0.82	1.00	0.796	1.024
27-31			16UI							3.52	4K	3.30	3.74	3.174
33-37	7.52	2.5 kHz		7.10		7.94	6.756	8.164						
39-43	50	64		FIXED		33	50Hz	30.82	35.18					

Performance Tests

**SDH Transmit/Receive Jitter Amplitude Accuracy**

**STM-4 Optical**

**49** Change Transmit/Receive Rate to STM-4 Optical with AU4-4C Mapped Bulk Filled 2<sup>23</sup> PRBS Payload. Check and adjust the optical power as necessary. Ensure Jitter is OFF and Calibration Pattern is OFF, then repeat steps 6 to 43 using the information in the Table below for STM-4.

STEP	TX Range	RX Range	RX Filter	Tx UI p-p	Tx Freq	TX Result MIN p-p	TX Result MAX p-p	RX Result MIN p-p	RX Result MAX p-p
6-8	OFF	1.6UI	LP+HP2	OFF	OFF	OFF	OFF	N/A	0.070
9	OFF	1.6UI	LP+HP1	OFF	OFF	OFF	OFF	N/A	0.070
13-15	20	1.6UI	LP+HP1	0.2	250K	0.15	0.25	0.116	0.284
16-20			LP+HP2		2.5M	0.15	0.25	0.111	0.291
22-25			LP+HP1	0.91	25K	0.82	1.00	0.776	1.044
27-31		16UI		3.52	10K	3.30	3.74	3.174	3.866
33-37				11.52	5K	10.90	12.14	10.401	12.426
39-43	200	256	FIXED	132	50Hz	124.37	139.63	113.40	150.60

Performance Tests

**SDH Transmit/Receive Jitter Amplitude Accuracy**

**STM-16 Optical**

**50** .Change Transmit/Receive Rate to STM-16 Optical with AU4-16C Mapped Bulk Filled 2<sup>23</sup> PRBS Payload. Check and adjust the optical power as necessary. Ensure Jitter is OFF and Calibration Pattern is OFF, then repeat steps 6 to 43 using the information in the Table below for STM-16.

STEP	Tx Range	RX Range	RX Filter	Tx UI p-p	Tx Freq	TX Result MIN p-p	TX Result MAX p-p	RX Result MIN p-p	RX Result MAX p-p
6-8	OFF	1.6UI	LP+HP2	OFF	OFF	OFF	OFF	N/A	0.070
9	OFF	1.6UI	LP+HP1	OFF	OFF	OFF	OFF	N/A	0.070
13-15	20	1.6UI	LP+HP1	0.2	1M	0.14	0.26	0.114	0.286
16-20			LP+HP2		10 M	0.13	0.27	0.100	0.300
22-25			LP+HP1		100K	0.81	1.01	0.795	1.026
27-31			64UI			3.52	50K	3.29	3.75
33-37	9.52	25K		8.99		10.05	8.53	10.34	
39-43	800	1024		FIXED		528	50Hz	499.60	556.40

**51** In the case of dual wavelength option units set to the alternative wavelength (1550nm) and repeat steps 6-9 for each rate.

## Performance Tests

### SDH Transmit/Receive Jitter Amplitude Accuracy

#### External Jitter Generation and Demod Output

- 1 Add the Synthesizer and oscilloscope to the set-up as shown below.

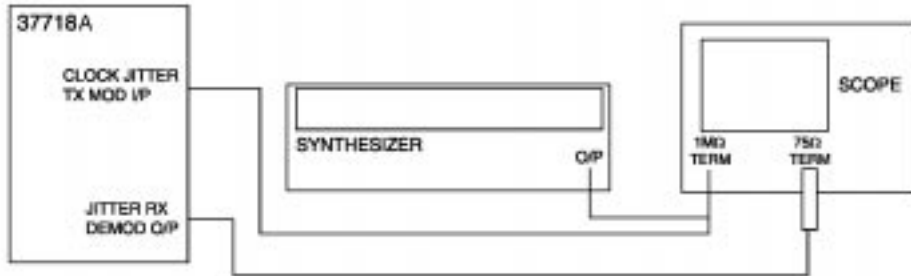

Figure 15

SDH External Jitter Generation and Demod Output Test Setup

- 2 Setup the HP 37718A **TRANSMIT** display as shown opposite.

TRANSMITTER OUTPUT		SDH		
MAIN	STRUCT'D	JITTER	TEST	OVERHEAD
SETTINGS	PAYLOAD	FUNCTION	SETUP	
SIGNAL	STM-1 OPT	1310nm	INTERNAL	
CLOCK	INTERNAL			
FREQUENCY	OFFSET	OFF		
MAPPING	<input checked="" type="checkbox"/> AU-4		BACKGROUND	
			UC-4	
			BULK FILLED	
PATTERN	2*23-1 PRBS	INVERT	ITU	

STATUS:

**MULTIPLE WINDOW**

## Performance Tests

### SDH Transmit/Receive Jitter Amplitude Accuracy

- 3 Select TRANSMITTER OUTPUT SETTINGS **JITTER** and setup the display as shown opposite.

TRANSMITTER OUTPUT		SDH	
MAIN SETTINGS	STRUCT'D PAYLOAD	JITTER	TEST FUNCTION OVERHEAD SETUP
JITTER / WANDER		JITTER	
JITTER		ON	
SIGNAL FREQUENCY		155Mb/s	OPT
MODULATION SOURCE		INTERNAL	
CLOCK SYNC		INTERNAL	
EXT JITTER MODULATION	0.00	UI	pk-pk

STATUS:

**MULTIPLE WINDOW**

- 4 Select RECEIVER INPUT SETTINGS **JITTER** and setup the display as shown opposite.

RECEIVER INPUT		SDH	
MAIN SETTINGS	STRUCT'D PAYLOAD	JITTER	TEST FUNCTION MONITOR OVERHEAD
MEASUREMENT TYPE		JITTER	
SIGNAL FREQUENCY		155Mb/s	OPT
RECEIVER RANGE		1.6	UI
HIT THRESHOLD		1.00	UI
FILTER		LP+HP1	

STATUS:

**MULTIPLE WINDOW**

- 5 Set the Calibration Pattern to ALT.
- 6 Set the Spectrum Analyzer as follows:  
Centre Frequency - 77.76 MHz (half bit rate being tested)  
Frequency Span - 30 kHz (approx 3 times the Jitter frequency)  
Reference Level - approx -15dBm  
Sweep Time - Auto  
Video Bandwidth - Auto  
Resolution Bandwidth - Auto
- 7 Set the Synthesizer to Frequency 10 kHz and minimum Output level.
- 8 Increase the Synthesizer output level until the Carrier and first sidebands are equal as observed on the Spectrum Analyzer (see Figure 3-11).

## Performance Tests

### **SDH Transmit/Receive Jitter Amplitude Accuracy**

- 9** Check that the Synthesizer amplitude waveform on the Oscilloscope is between 364 and 546 mV pk\_pk.
- 10** Check that the HP 37718A Demod Output amplitude waveform on the Oscilloscope is between 756 mV and 1.075 V pk\_pk.
- 11** Set the Calibration Pattern to OFF and set Jitter to OFF.

Performance Tests

**SDH Transmit/Receive Jitter Amplitude Accuracy**



Performance Tests  
**Performance Test Record**

---

**Performance Test Record**

<b>Hewlett-Packard Model 37718/37719A 2.5 Gb/s Multirate Communications Performance Analyzer</b>	
<b>Location:</b>	<b>Serial No.:</b>
<b>Tested by:</b>	<b>Options:</b>
<b>Temperature:</b>	<b>Certified by:</b>
<b>Humidity:</b>	<b>Date:</b>

Note the test steps applicable are dependent on the instrument options and bit rates available. Enter N/A if a test does not apply for your instrument .

---

**Table 6 Performance Test Record**

<b>Page No.</b>	<b>Test Description</b>		<b>Min</b>	<b>Result Actual</b>	<b>Max</b>
	<b>Self Test</b>				
3-6	Step3	Confidence Tests		Pass/Fail	
3-7	Step 4	All Tests		Pass/Fail	
3-8	Step 3	1550nm Tests		Pass/Fail	
3-9	Step 3	DCC Tests		Pass/Fail	
	<b>PDH/DSn Internal Transmitter Clock Accuracy &amp; Offset</b>				
3-11	Step 4:	2 Mb/s	1.023995 MHz		1.024005 MHz
	Step 6:	2 Mb/s +50ppm	1.0240465 MHz		1.0240555 MHz
	Step 8:	2 Mb/s -50ppm	1.023944 MHz		1.023953 MHz
3-12	Step 10:	8 Mb/s	4.223981 MHz		4.224019 MHz
	Step 12:	8 Mb/s +30ppm	4.2241075 MHz		4.2242915 MHz
	Step 14:	8 Mb/s -30ppm	4.223854 MHz		4.223892 MHz

Performance Tests  
**Performance Test Record**

**Table 6** Performance Test Record continued

Page No.	Test Description		Min	Result Actual	Max
3-12	Step 16:	34 Mb/s	17.18389227 MHz		17.1840774 MHz
	Step 18:	34 Mb/s +20ppm	17.184266 MHz		17.184421 MHz
	Step 20:	34 Mb/s -20ppm	17.183579 MHz		17.183734 MHz
	Step 22:	34 Mb/s +100ppm	17.185641 MHz		17.185796 MHz
	Step 24:	34 Mb/s -100ppm	17.182205 MHz		17.182359 MHz
3-13	Step 26:	140 Mb/s	69.6316865 MHz		69.6323185 MHz
	Step 28:	140 Mb/s +15ppm	69.632731 MHz		69.633358 MHz
	Step 30:	140 Mb/s -15ppm	69.630642 MHz		69.631269 MHz
	Step 33:	1.544 Mb/s	1.543993 MHz		1.544007 MHz
	Step 35:	1.544 Mb/s +32ppm	1.544042 MHz		1.544056 MHz
	Step 37:	1.544 Mb/s -32ppm	1.543944 MHz		1.543958 MHz
3-14	Step 40:	44.736 Mb/s	44.735799 MHz		44.736201 MHz
	Step 42:	44.736 Mb/s +20ppm	44.736693 MHz		44.737096 MHz
	Step 44:	44.736 Mb/s -20ppm	44.734904 MHz		44.735307 MHz
	<b>PDH/DSn Transmitter Output</b>				
3-16		<b>139.264Mb/s (E4)</b>			
	Step 7:	All 1's Pulse		Pass/Fail	
	Step 8:	Pulse amplitude	0.45V pk		0.55V pk
	Step 12:	All 0's Pulse		Pass/Fail	
	Step 13:	Pulse amplitude	0.45V pk		0.55V pk
3-19		<b>34.368Mb/s (E3)</b>			
	Step 7:	+ve Pulse		Pass/Fail	
	Step 8:	+ve Pulse amplitude	0.900V pk		1.100V pk
	Step 12:	-ve Pulse		Pass/Fail	
	Step 13:	-ve Pulse amplitude	0.900V pk		1.100V pk

Performance Tests  
**Performance Test Record**

**Table 6** **Performance Test Record continued**

<b>Page No.</b>	<b>Test Description</b>	<b>Min</b>	<b>Result Actual</b>	<b>Max</b>
3-21	<b>8.448Mb/s (E2)</b>			
	Step 7: +ve Pulse		Pass/Fail	
	Step 8: +ve Pulse amplitude	0.900V pk		1.100V pk
	Step 12: -ve Pulse		Pass/Fail	
	Step 13: -ve Pulse amplitude	0.900V pk		1.100V pk
3-23	<b>2.048Mb/s (E1)</b>			
	Step 7: +ve Pulse		Pass/Fail	
	Step 8: +ve Pulse amplitude	2.133V pk		2.607V pk
	Step 12: -ve Pulse		Pass/Fail	
	Step 13: -ve Pulse amplitude	2.133V pk		2.607V pk
3-26	<b>44.736Mb/s (DSX3)</b>			
	Step 7: +ve Pulse		Pass/Fail	
	Step 8: +ve Pulse amplitude		Pass/Fail	
	Step 12: -ve Pulse		Pass/Fail	
	Step 13: -ve Pulse amplitude		Pass/Fail	
	Step 14: High amplitude		Pass/Fail	
	Step 15: Low amplitude		Pass/Fail	
3-28	<b>1.544Mb/s (DSX1)</b>			
	Step 7: +ve Pulse		Pass/Fail	
	Step 8: +ve Pulse amplitude	1.984V pk		2.976V pk
	Step 12: -ve Pulse		Pass/Fail	
	Step 13: -ve Pulse amplitude	1.984V pk		2.976V pk
	Step 14: Low amplitude		Pass/Fail	

Performance Tests  
**Performance Test Record**

**Table 6** Performance Test Record continued

Page No.	Test Description	Min	Result Actual	Max
3-32	<b>PDH/DSn Receiver Equalization</b>			
	Step 6: 139.264Mb/s (E4)		Pass/Fail	
	Step 11: 34.368Mb/s (E3)		Pass/Fail	
	Step 16: 8.448 Mb/s (E2)		Pass/Fail	
	Step 21: 2.048Mb/s (E1)		Pass/Fail	
	Step 26: 44.736Mb/s (DS3)		Pass/Fail	
	Step 31: 1.544Mb/s (DS1)		Pass/Fail	
3-39	<b>PDH/DSn Receiver Monitor Levels</b>			
3-40	<b>2.048Mb/s (E1)</b>			
	Step 5: 20dB		Pass/Fail	
	Step 10: 20dB & Equalization		Pass/Fail	
	Step 14: 26dB & Equalization		Pass/Fail	
	Step 18: 26dB		Pass/Fail	
	Step 22: 30dB		Pass/Fail	
	Step 26: 30dB & Equalization		Pass/Fail	
3-42	<b>8.448Mb/s (E2)</b>			
	Step 27: 20dB		Pass/Fail	
	Step 27: 20dB & Equalization		Pass/Fail	
	Step 27: 26dB & Equalization		Pass/Fail	
	Step 27: 26dB		Pass/Fail	
	Step 27: 30db		Pass/Fail	
	Step 27: 30dB & Equalization		Pass/Fail	
3-42	<b>34.368Mb/s (E3)</b>			
	Step 28: 20dB		Pass/Fail	

Performance Tests  
**Performance Test Record**

**Table 6** Performance Test Record continued

<b>Page No.</b>	<b>Test Description</b>		<b>Min</b>	<b>Result Actual</b>	<b>Max</b>
	Step 28:	20dB & Equalization		Pass/Fail	
	Step 28:	26dB & Equalization		Pass/Fail	
	Step 28:	26dB		Pass/Fail	
3-42		<b>139.264Mb/s (E3)</b>			
	Step 29:	20dB		Pass/Fail	
	Step 29:	20dB & Equalization		Pass/Fail	
	Step 29:	26dB & Equalization		Pass/Fail	
	Step 29:	26dB		Pass/Fail	
3-43		<b>1.544Mb/s (DS1)</b>			
	Step 30:	20dB		Pass/Fail	
	Step 30:	20dB & Equalization		Pass/Fail	
	Step 30:	26dB & Equalization		Pass/Fail	
	Step 30:	26dB		Pass/Fail	
	Step 30:	30db		Pass/Fail	
	Step 30:	30dB & Equalization		Pass/Fail	
3-43		<b>44.736Mb/s (E3)</b>			
	Step 31:	20dB		Pass/Fail	
	Step 31:	20dB & Equalization		Pass/Fail	
	Step 31:	26dB & Equalization		Pass/Fail	
	Step 31:	26dB		Pass/Fail	
3-44	<b>External Mux/Demux</b>				
	Step 9:	2 Mb/s Bit & Code EC		Pass/Fail	
	Step 10:	2 Mb/s Bit Error Add		Pass/Fail	
	Step 15:	+ve Mask 2 Mb/s			
	Step 16:	+ve Amp 2 Mb/s	2.133 V pk		2.607 V pk
	Step 20	-ve Mask 2 Mb/s		Pass/Fail	

Performance Tests  
**Performance Test Record**

**Table 6** Performance Test Record continued

Page No.	Test Description		Min	Result Actual	Max
	Step 21:	-ve Amp 2Mb/s	2.133 V pk		2.607 V pk
	Step 1:	DS-1 Bit & Code EC		Pass/Fail	
	Step 1:	DS-1 Bit Error Add		Pass/Fail	
	Step 6:	+ve Pulse Mask DS-1		Pass/Fail	
	Step 7:	+ve Pulse Amp DS-1	1.896 V pk		2.844 V
	Step 11	-ve Pulse Mask DS-1		Pass/Fail	
	Step 12:	-ve Pulse Amp DS-1	1.896 V pk		2.844 V pk
3-54	<b>PDH Frequency Measurement and Looped Clock</b>				
	Step 8:	2Mb/s frequency	2.047991 MHz		2.048009 MHz
	Step 9:	Offset (0 ppm)	-4.5 ppm		+4.5 ppm
	Step 10:	Frequency+100 ppm	2.048194 MHz		2.048214 MHz
	Step 11:	Offset +100 ppm	+95.5 ppm		+104.5 ppm
	Step 12:	Frequency-100 ppm	2.047786 MHz		2.047806 MHz
	Step 13:	Offset -100 ppm	-95.5 ppm		-104.5 ppm
	Step 13:	Frequency Counter		Pass/Fail	
	Step 14:	8Mb/s 0 ppm	-4.5 ppm		+4.5 ppm
	Step 14:	8Mb/s -100 ppm	-95.5 ppm		-104.5 ppm
	Step 14:	8Mb/s +100 ppm	+95.5 ppm		+104.5 ppm
	Step 14:	34 Mb/s 0 ppm	-4.5 ppm		+4.5 ppm
	Step 14:	34 Mb/s -100 ppm	-95.5 ppm		-104.5 ppm
	Step 14:	34 Mb/s +100 ppm	+95.5 ppm		+104.5 ppm
	Step 14:	40 Mb/s 0 ppm	-4.5 ppm		+4.5 ppm
	Step 14:	140 Mb/s -100 ppm	-95.5 ppm		-104.5 ppm
	Step 14:	140 Mb/s +100 ppm	+95.5 ppm		+104.5 ppm

Performance Tests  
**Performance Test Record**

**Table 6** Performance Test Record continued

<b>Page No.</b>	<b>Test Description</b>		<b>Min</b>	<b>Result Actual</b>	<b>Max</b>
	Step 14:	1.544Mb/s 0 ppm	-4.5 ppm		+4.5 ppm
	Step 14:	1.544Mb/s -100 ppm	-95.5 ppm		-104.5 ppm
	Step 14:	1.544Mb/s +100 ppm	+95.5 ppm		+104.5 ppm
	Step 14:	44.736Mb/s 0 ppm	-4.5 ppm		+4.5 ppm
	Step 14:	44.736Mb/s -100 ppm	-95.5 ppm		-104.5 ppm
	Step 14:	44.736Mb/s+100 ppm	+95.5 ppm		+104.5 ppm
3-58	<b>SDH/SONET Transmitter Clock Accuracy</b>				
	Step 4:	Frequency	51.839670 MHz		51.840230 MHz
3-59	<b>External MTS Clock</b>				
	Step 7:	2Mb/s Clock		Pass/Fail	
	Step 9:	Ref Clock Out		Pass/Fail	
	Step 16:	2Mb/s Data		Pass/Fail	
	Step 21:	2Mb/s Data Balanced		Pass/Fail	
	Step 25:	Rx Data Clock Loss		Pass/Fail	
	Step 28:	Rx Data Clock Gain		Pass/Fail	
	Step 30:	10 MHz Clock Loss		Pass/Fail	
	Step 33:	10MHz Clock Gain		Pass/Fail	
	Step 35:	BITS Clock Loss		Pass/Fail	
	Step 38:	BITS Clock Gain		Pass/Fail	
	Step 41:	64kb/s Clock Loss		Pass/Fail	
	Step 42:	64kb/s Clock Gain		Pass/Fail	
3-64	<b>SDH/SONET Offsets</b>				
	Step 5:	Clock Loss		Pass/Fail	
	Step 10:	0ppm		51.84MHz	
	Step 11:	-999ppm	51.7882108MHz		51.7882129MHz

Performance Tests  
**Performance Test Record**

**Table 6** Performance Test Record continued

Page No.	Test Description		Min	Result Actual	Max
	Step 11:	-100ppm	51.8348149MHz		51.8348171MHz
	Step 11:	-66ppm	51.8365464MHz		51.8365485MHz
	Step 11:	+33ppm	51.8417252MHz		51.8417273MHz
	Step 11:	+100ppm	51.8451829MHz		51.8451851MHz
	Step 11:	+999ppm	51.8917871MHz		51.8917892MHz
3-66	<b>STM-0/STS-1 Transmitter Output Waveshape</b>				
	Step 6:	+ve Pulse		Pass/Fail	
	Step 7:	+ve Pulse Amp		Pass/Fail	
	Step 11:	-ve Pulse		Pass/Fail	
	Step 12:	-ve Pulse Amp		Pass/Fail	
	Step 13:	High amplitude		Pass/Fail	
	Step 14:	Low Amplitude		Pass/Fail	
3-70	<b>STM-1/STS-3 Transmitter Output Waveshape</b>				
	Step 8:	All 1's Pulse		Pass/Fail	
	Step 9:	Pulse Amp	450 mV pk		550 mV pk
	Step 13:	All 0's Pulse		Pass/Fail	
	Step 14:	Pulse Amp	450 mV pk		550 mV pk
3-75	<b>SDH/SONET Receiver Equalization</b>				
	Step 5:	STM-0/STS-1		Pass/Fail	
	Step 10:	STM-1/STS-3		Pass/Fail	
3-78	<b>SDH/SONET Receiver Monitor Levels</b>				
		<b>STM-0/STS-1</b>			
	Step 5:	20dB		Pass/Fail	



Performance Tests  
**Performance Test Record**

**Table 6** Performance Test Record continued

<b>Page No.</b>	<b>Test Description</b>		<b>Min</b>	<b>Result Actual</b>	<b>Max</b>
	Step 9:	20dB + Equalization		Pass/Fail	
	Step 14:	26dB + Equalization		Pass/Fail	
	Step 18:	26dB		Pass/Fail	
		<b>STM-1/STS-3</b>			
	Step 20:	20dB		Pass/Fail	
	Step 20:	20dB + Equalization		Pass/Fail	
	Step 20:	26dB + Equalization		Pass/Fail	
	Step 20:	26dB		Pass/Fail	
3-82	<b>Multirate Optical Interface</b>				
		<b>Power 1310nm</b>			
	Step 6:	STM-0/OC-1	0 dBm		+3 dBm
	Step 8:	STM-1/OC-3	0 dBm		+3 dBm
	Step 10:	STM-4/OC-12	0 dBm		+3 dBm
	Step 12:	STM-16/OC-48	0 dBm		+3 dBm
		<b>Sensitivity 1310nm</b>			
	Step 22:	STM-0/OC-1		Pass/Fail	
	Step 23:	STM-1/OC-3		Pass/Fail	
	Step 24:	STM-4/OC-12		Pass/Fail	
	Step 25:	STM-16/OC-48		Pass/Fail	
		<b>PMP input</b>			
	Step 35:	STM-0/OC-1		Pass/Fail	
	Step 38:	STM-1/OC-3		Pass/Fail	
	Step 41:	STM-4/OC-12		Pass/Fail	
		<b>Power 1550nm</b>			
	Step 42:	STM-0/OC-1	0 dBm		+3 dBm
	Step 42:	STM-1/OC-3	0 dBm		+3 dBm

Performance Tests  
**Performance Test Record**

**Table 6** **Performance Test Record continued**

Page No.	Test Description		Result		
			Min	Actual	Max
	Step 42:	STM-4/OC-12	0 dBm		+3 dBm
	Step 42:	STM-16/OC-48	0 dBm		+3 dBm
		<b>Sensitivity 1550nm</b>			
	Step 43:	STM-0/OC-1		Pass/Fail	
	Step 43:	STM-1/OC-3		Pass/Fail	
	Step 43:	STM-4/OC-12		Pass/Fail	
	Step 43:	STM-16/OC-48		Pass/Fail	

Performance Tests

**Jitter Performance Test Record (options 204, 205 & 206)**

---

**Jitter Performance Test Record (options 204, 205 & 206)**

<b>Hewlett-Packard Model 37718A 2.5 Gb/s Multirate Communications Performance Analyzer (Jitter options only)</b>	
<b>Location:</b>	<b>Serial No.:</b>
<b>Tested by:</b>	<b>Options:</b>
<b>Temperature:</b>	<b>Certified by:</b>
<b>Humidity:</b>	<b>Date:</b>

Table 7

**Performance Test Record**

Page No.	Test Description	Min	Result Actual	Max
3-89	<b>PDH Tx/Rx Jitter Amplitude Accuracy</b>			
	Step 8 AIS LED On		Pass/Fail	
	Step 12 2048 kHz - Tx	0.69 UI		0.83
	Step 12 2048 kHz - Rx	0.711 UI		0.829 UI
	Step 12 8448 kHz - Tx	0.69 UI		0.83 UI
	Step 12 8448 kHz - Rx	0.706 UI		0.834 UI
	Step 12 34368 kHz - Tx	0.69 UI		0.83 UI
	Step 12 34368 kHz - Rx	0.706 UI		0.834 UI
	Step 12 139264 kHz - Tx	0.68 UI		0.84 UI
	Step 12 139264 kHz - Rx	0.706 UI		0.834 UI
	Step 19 AIS LED On		Pass/Fail	
	Step 22 2048 kHz - Null 1.8 UI	Tx 1.5 UI		Tx 2.0 UI
	2048 kHz - Null 1.8 U	Rx 1.587 UI		Rx 1.933 UI
	2048 kHz - Null 4.8 UI	Tx 4.4 UI		Tx 5.1 UI

Performance Tests  
**Jitter Performance Test Record (options 204, 205 & 206)**

**Table 7** Performance Test Record continued

Page No.	Test Description		Result		
			Min	Actual	Max
	Step 22	2048 kHz - Null 4.8 UI	Rx 4.377 UI		Rx 5.143 UI
		2048 kHz - Null 8.8 UI	Tx 8.2 UI		Tx 9.3 UI
		2048 kHz - Null 8.8 UI	Rx 8.097 UI		Rx 9.423 UI
		8448 kHz - Null 1.8 UI	Tx 1.5 UI		Tx 2.0 UI
		8448 kHz - Null 1.8 UI	Rx 1.587 UI		Rx 1.933 UI
		8448 kHz - Null 5.8 UI	Tx 5.3 Ui		Tx 6.2 UI
		8448 kHz - Null 5.8 UI	Rx 5.307 UI		Rx 6.213 UI
		8448 kHz - Null 8.8 UI	Tx 8.2 Ui		Tx 9.3 UI
		8448 kHz - Null 8.8 UI	Rx 8.097 UI		Rx 9.423 UI
		34368 kHz-Null 2.8 UI	Tx 2.5 Ui		Tx 3.0 UI
		34368 kHz-Null 2.8 UI	Rx 2.517 UI		Rx3.003 UI
		34368 kHz-Null 6.8 UI	Tx 6.2 UI		Tx 7.3 UI
		34368 kHz-Null 6.8 UI	Rx 6.237 UI		Rx 7.283 UII
		34368 kHz-Null 8.8 UI	Tx 8.2 Ui		Tx 9.3 UI
		34368 kHz-Null 8.8 UI	Rx 8.097 UI		Rx 9.423 UI
		139264 kHz Null 3.8	Tx 3.3 Ui		Tx 4.2 UI
		139264 kHz Null 3.8	Rx 3.447 UI		Rx 4.073 UI
		139264 kHz Null 7.8	Tx 7.1 Ui		Tx 8.4 UI
		139264 kHz Null 7.8	Rx 7.167 Ui		Rx 8.353 UI
		139264 kHz Null 8.8	Tx 8.1 UI		Tx 9.4 UI
		139264 kHz Null 8.8	Rx 8.097 UI		Rx 9.423 UI
	<b>PDH Demod Output Amp.</b>				
3-98	Step 9	Demod Output Amp.	707 mV p-p		833 mV p-p

Performance Tests

**Jitter Performance Test Record (options 204, 205 & 206)**

Table 7

**Performance Test Record continued**

Page No.	Test Description		Min	Result Actual	Max
3-101	<b>SDH Tx/Rx Jitter Amplitude Accuracy</b>				
	<b>STM1 Electrical</b>				
	Step 8	No SDH result errors		Pass/Fail	
	Step 8	Jitter result			<0.050 UI p-p
	Step 9:	Jitter result			<0.050 UI p-p
	Step 14:	No SDH errors		Pass/Fail	
	Step 15:	Tx Jitter results	0.06 UI p-p		0.14 UI p-p
		Rx Jitter results	0.043 UI p-p		0.157 UI p-p
	Step 19	No SDH errors		Pass/Fail	
	Step 20	Tx results	0.06 UI p-p		0.14 UI p-p
		Rx Jitter results	0.042 UI p-p		0.158 UI p-p
	Step 24	No SDH errors		Pass/Fail	
	Step 25	Tx Jiter results	0.82UI p-p		1.00 UI p-p
		Rx Jitter results	0.796 UI p-p		1.024 UI p-p
	Step 30	No SDH errors		Pass/Fail	
	Step 31	Tx Jitter results	3.30 UI p-p		3.74 UI p-p
		Rx Jitter Results	3.204 UI p-p		3.836 UI p-p
	Step 35	No SDH errors		Pass/Fail	
	Step 36	Tx Jitter results	7.10 UI p-p		7.94 UI p-p
		Rx Jitter results	6.756 UI p-p		8.164 UI p-p
	Step 41	No SDH errors		Pass/Fail	
	Step 42	Tx Jitter result	30.82 UI p-p		35.18 UI p-p
		Rx Jitter result	28.350 UI p-p		37.650 UI p-p

Performance Tests  
**Jitter Performance Test Record (options 204, 205 & 206)**

**Table 7** Performance Test Record continued

Page No.	Test Description		Min	Result Actual	Max
3-114	<b>STM1 Optical</b>				
	Step 47	Optical Power dBm	N/A		N/A/
	Step 48	step 8 No SDH errors		Pass/Fail	
		step 8 Rx result	N/A		0.050 UI p-p
		step 9 Rx result	N/A		0.050 UI p-p
	Step 48	step 13-15 Tx result	0.15 UI p-p		0.25 UI p-p
		step 13-15 Rx result	0.136 UI p-p		0.264 UI p-p
		step 14 No SDH errors		Pass/Fail	
		step 18-20 Tx result	0.15 UI p-p		0.25 UI p-p
		step 18-20 Rx result	0.134 UI p-p		0.266 UI p-p
		step 19 No SDH errors		Pass/Fail	
		step 22-25 Tx result	0.82UI p-p		1.00 UI p-p
		step 22-25 Rx result	0.796 UI p-p		1.024 UI p-p
		step 24 No SDH errors		Pass/Fail	
		step 27-31 Tx result	3.30 UI p-p		3.74 UI p-p
		step 27-31 Rx result	3.174 UI p-p		3.866 UI p-p
		step 30 No SDH errors		Pass/Fail	
		step 33-37 Tx result	7.10 Ui p-p		7.94 UI p-p
		step 33-37 Rx result	6.756 UI p-p		8.164 UI p-p
		step 35 No SDH errors		Pass/Fail	
		step 39-43 Tx result	30.82 UI p-p		35.18 UI p-p
		step 39-43 Rx result	28.350 UI p-p		37.650 UI p-p

Performance Tests  
**Jitter Performance Test Record (options 204, 205 & 206)**

**Table 7** Performance Test Record continued

Page No.	Test Description		Min	Result Actual	Max
		step 41 No SDH errors		Pass/Fail	
3-115	<b>STM 4 Optical</b>				
	Step 49	Optical Power dBm	N/A		N/A
		step 8 No SDH errors		Pass/Fail	
		step 8 Rx result	N/A		0.070 UI p-p
		step 9 Rx result	N/A		0.070 UI p-p
		step 13-15 Tx result	0.15 UI p-p		0.25 UI p-p
		step 13-15 Rx result	0.118 UI p-p		0.284 UI p-p
		step 14 No SDH errors		Pass/Fail	
		step 18-20 Tx result	0.15 UI p-p		0.25 UI p-p
		step 18-20 Rx result	0.111 UI p-p		0.291 UI p-p
		step 19 No SDH errors		Pass/Fail	
		step 22-25 Tx result	0.82 UI p-p		1.00 UI p-p
		step 22-25 Rx result	0.776 UI p-p		1.044 UI p-p
		step 24 No SDH errors		Pass/Fail	
		step 27-31 Tx result	3.30 UI p-p		3.74 UI p-p
		step 27-31 Rx result	3.174 UI p-p		3.866 UI p-p
		step 30 No SDH errors		Pass/Fail	
		step 33-37 Tx result	10.90 Ui p-p		12.14 UI p-p
		step 33-37 Rx result	10.401 UI p-p		12.426 UI p-p
		step 35 No SDH errors		Pass/Fail	

Performance Tests  
**Jitter Performance Test Record (options 204, 205 & 206)**

**Table 7** Performance Test Record continued

Page No.	Test Description		Result		
			Min	Actual	Max
		step 39-43 Tx result	124.37 UI p-p		139.63 UI p-p
	Step 49	step 39-43 Rx result	113.40 UI p-p		150.60 UI p-p
		step 41 No SDH errors		Pass/Fail	
3-116	<b>STM 16 Optical</b>				
	Step 50	Optical Power dBm	N/A		N/A
		step 8 No SDH errors		Pass/Fail	
		step 8 Rx result	N/A		0.070 UI p-p
		step 9 Rx result	N/A		0.070 UI p-p
		step 13-15 Tx result	0.14 UI p-p		0.26 UI p-p
		step 13-15 Rx result	0.114 UI p-p		0.286 UI p-p
		step 14 No SDH errors		Pass/Fail	
		step 18-20 Tx result	0.13 UI p-p		0.27 UI p-p
		step 18-20 Rx result	0.100 UI p-p		0.300 UI p-p
		step 19 No SDH errors		Pass/Fail	
		step 22-25 Tx result	0.81 UI p-p		1.01 UI p-p
		step 22-25 Rx result	0.795 UI p-p		1.026 UI p-p
		step 24 No SDH errors		Pass/Fail	
		step 27-31 Tx result	3.29 UI p-p		3.75 UI p-p
		step 27-31 Rx result	3.124 UI p-p		3.916 UI p-p
		step 30 No SDH errors		Pass/Fail	
		step 33-37 Tx result	8.99 Ui p-p		10.05 UI p-p
		step 33-37 Rx result	8.53 UI p-p		10.34 UI p-p



Performance Tests

**Jitter Performance Test Record (options 204, 205 & 206)**

Table 7

**Performance Test Record continued**

Page No.	Test Description		Min	Result Actual	Max
		step 35 No SDH errors		Pass/Fail	
		step 39-43 Tx result	499.60 UI p-p		556.40 UI p-p
		step 39-43 Rx result	451.60 UI p-p		604.40 UI p-p
		step 41 No SDH errors		Pass/Fail	
3-116	Step 51	<b>STM-1 Optical</b>			
		step 8 Rx result	N/A		0.050 UI p-p
		step 8 No SDH errors		Pass/Fail	
		step 9 Rx result	N/A		0.050 UI p-p
3-116	Step 51	<b>STM-4 Optical</b>			
		step 8 Rx result	N/A		0.070 UI p-p
		step 8 No SDH errors		Pass/Fail	
		step 9 Rx result	N/A		0.070 UI p-p
3-116	Step51	<b>STM-16 Optical</b>			
		step 8 Rx result	N/A		0.070 UI p-p
		step 9 Rx result	N/A		0.070 UI p-p
		step 8 No SDH errors		Pass/Fail	
		<b>SDH Ext. Jitter Generation/ Demod Output</b>			
3-117	Step 9	Input Tx mod.	364mV p-p		546 mV p-p
	Step 10	Demod O/P Amp	756 mV p-p		1.075 V p-p

Performance Tests

**Jitter Performance Test Record (options 204, 205 & 206)**

# 4 Terms

This section contains Tables of ETSI Terms with their ANSI equivalents and current terms with their equivalent earlier terms.

---

## ETSI/ANSI Conversion and Equivalent Terms

### Introduction

The terminology used on the instrument display can be ETSI (SDH) or ANSI (SONET) terminology. Refer to the table given in this chapter for an explanation of equivalent SDH/SONET terms.

ETSI: European Telecommunications Standards Institute.

ANSI: American National Standards Institute.

---

**Table 1 ETSI / ANSI Terminology**

ETSI Term	ANSI Term
AU-3	STS-1 SPE + H1, H2, H3
AU-4	STS-3c SPE + H1, H2, H3
BIP (Bit Interleaved parity)	CV (Code Violation)
High Order Path (HP / HO)	STS Path
I-n Intra Office, (n=STM-n level)	Intermediate Reach (IR)
L-n.1 or L-n.2 long haul	LR long reach
Low Order Path (LP / LO)	VT Path
LP-REI	REI-V
M.S.P	A.P.S

**ETSI/ANSI Conversion and Equivalent Terms****Table 1 ETSI / ANSI Terminology , continued**

<b>ETSI Term</b>	<b>ANSI Term</b>
Multiplexer Section (MS)	Line
Multiplexer Section Protection	Automatic Protection Switching
MS-AIS	Line AIS / AIS-L
MS-BIP	Line CV / CV-L
MS-DCC	Line DCC / DCC-L
MS-REI	Line FEBE / REI-L
MS-RDI	Line FERF / RDI-L
Multiplexer Section Overhead	Line Overhead
Network Node Interface	Line Interface
OOF	SEF (severely errored frame defect)
Path AIS / AU-AIS	AIS-P
Path REI / HP REI	REI-P
Path FERF / HP RDI	RDI-P
Path IEC / AU-IEC	IEC-P
Path Overhead	Path Overhead
Regenerator	Repeater
Regenerator Section (RS)	Section
Regenerator Section Overhead	Section Overhead
Remote Alarm Indicator	RAI
RS-DCC	Section DCC (DCC-S)
Section Overhead (SOH)	Transport Overhead (TOH)
S-n.1 or S-n.2 short haul	Short Reach (SR)
SOH	TOH

**ETSI/ANSI Conversion and Equivalent Terms****Table 1 ETSI / ANSI Terminology , continued**

ETSI Term	ANSI Term
STM-m	OC-n / STS-n (where $m = n + 3$ for $m \geq 1$ )
STM-0	STS-1
STM-1	OC3c / STS-3c
STM-4	OC-12 / STS-12
STM-16	OC-48 / STS-48
Tributary Unit (TU)	Virtual Tributary (VT)
TU	VT
TU-11	VT 1.5
TU-12	VT 2
TU-2	VT 6
TU-3	NONE
TU BIP	VT BIP (CV-V)
TU RDI / LP-RDI	RDI-V
TUG	VT Group
TUG2	VT Group (12 columns)
TUG3	VT Group (86 columns)
TU multiframe	VT superframe
TU PATH AIS	VT AIS (AIS-V)
VC	SPE
VC4	STS3C SPE
Virtual Container (VC)	Synchronous Payload Envelope (SPE)

NOTE: VC is an ETSI abbreviation for Virtual Container and an ETSI / ANSI abbreviation for (ATM) Virtual Channel. The context of VC must therefore be taken into account when converting between standards.

Installation  
**ETSI/ANSI Conversion and Equivalent Terms**

# 5

## Self Test Overview

---

### Self Tests

This section gives a overview of the Self Tests and their function.

Note - For SONET only option instruments, HP 37719A the equivalent SONET rate is used in SDH subtests.

There are several Self Test selections. Some providing overall functional tests and others provide specific measurement hardware/functions tests.

### OVERALL FUNCTION SELF TESTS

#### Confidence Test (test time - < 5 minutes depending on options)

Provides a quick verification of the main instrument functions using external Back to Back loopback of the instrument Transmit/Receive sections. See Table below for a list of the subtests and Figure 5-1 for the external loopback cabling required for this test. Use this test to provide a quick operational verification.

<u>Subtest</u>	<u>Test Function</u>
1	OPT 010 PDH 140Mb/s Structured 64kb/s
2	OPT 010 PDH 2Mb/s 120 ohm balanced
3	OPT 011 PDH 34Mb/s Structured 64kb/s
4	OPT 011 PDH DS1, D4 Structured 64kb/s
5	SDH, STM-0e Test
6	SDH, STM-0e Test
7	SDH, STM-1e Test
8	SDH, STM-1o Test
9	SDH, STM-4o Test
10	SDH, STM-16o Test
11	OPT 2xx Jitter Test, PDH 34Mb/s
12	OPT 2xx Jitter Test, SDH 622Mb/s

## Installation

### Self Tests

#### **All Tests (test time - up to 1 Hour depending on options)**

This provides an extensive Back to Back verification test of the instrument operation. The test uses much of the specific function tests, performing the appropriate subtest depending on options fitted. Test are run as follows.

**CPU test**

**CONFIDENCE test**

**PDH test**

**BER test (Note does not perform DCC port test)**

**JITTER test**

See Tables for each of these tests for a list of the subtests and Figure 5-1 for the loopback cabling required for this test. Note a Formatted floppy disk is required as the CPU test is run as part of All Tests selection.

Use this test to provide a comprehensive operational verification.

#### **SPECIFIC MEASUREMENT HARDWARE/FUNCTION TESTS**

##### **CPU Tests (test time - approximately 2 minutes)**

Provides a quick test of the Main and Front Panel processors. No external cabling is required, but formatted floppy disk must be installed.

<b><u>Subtest</u></b>	<b><u>Test Function</u></b>
<b>1</b>	<b>Flash ROM CRC checks</b>
<b>2</b>	<b>Ram Test</b>
<b>3-7</b>	<b>Not used</b>
<b>8</b>	<b>In-Lid Printer present check, (if option 602 fitted)</b>
<b>9</b>	<b>Not used</b>
<b>10</b>	<b>Floppy disk write/read</b>
<b>11</b>	<b>Not used</b>
<b>12-16</b>	<b>Front Panel processor checks</b>



## Installation

### Self Tests

#### **PDH Test (test time- approximately 20 minutes)**

Provides comprehensive test of the PDH Transmit/Receive sections. Note this test is run as part of ALL TESTS. The Subtests used are dependent on PDH option.

<u>Subtest</u>	<u>Test Function</u>
1-7	Line Code Tests (140/34/8/2 Mhz Unable 75 ohm)
8-9	Line Code Tests (2MHz Balanced 120 ohm)
10-21	Frequency Offset (140/34/8/2Mhz)
22-36	Error Add/Detect (34/2Mhz)
37-44	Framing (140/2Mhz)
45-53	Structured Payloads (140/34/8Mhz)
54-63	Patterns (140/34/8Mhz)
64	Drop/Insert (2Mhz)
65-72	Round Trip Delay (64Kb/s)
73-82	Not used
83-86	Line Code Tests (DS3/DS1 Unable 75 ohm)
87-88	Line Code Tests (DS1 Balanced 110 ohm)
89-94	Frequency Offset (DS3/DS1)
95-112	Error Add/Detect (DS3/DS1)
113-120	Framing (DS3/DS1)
121-130	Structured Payloads (DS3/DS1)
134-140	Patterns (DS3/DS1)
141	Drop/Insert (DS1)
142-145	Round Trip Delay (56Kb/s)

**BER Test (test time- approximately 20 minutes)**

These tests perform extensive test of the SDH/SONET Electrical and Optical Transmit/Receive sections. Note this test is run as part of ALL TESTS with the exception of Subtest 83, DCC port test.

<u>Subtest</u>	<u>Test Function</u>
<b>1</b>	<b>STM-16 MUX/DEMUX Internal Loopback</b>
<b>2-4</b>	<b>STM-0e Pulse Shape</b>
<b>5-8</b>	<b>Basic STM-0o Tx/Rx Test</b>
<b>7-8</b>	<b>Basic STM-1e Tx/Rx Test</b>
<b>9-10</b>	<b>Basic STM-1o Tx/Rx Test</b>
<b>11-12</b>	<b>Basic STM-4o Tx/Rx Test</b>
<b>13-14</b>	<b>Basic STM-16o Tx/Rx Test</b>
<b>15-17</b>	<b>STM-4o Frequency Measurement</b>
<b>18</b>	<b>STM-16o Frequency Measurement</b>
<b>19-20</b>	<b>Clock Reference Source</b>
<b>21-22</b>	<b>Optical Power Measurement</b>
<b>23</b>	<b>Overhead Byte Defaults [part 1]</b>
<b>24</b>	<b>Overhead Byte Defaults [part 2]</b>
<b>25</b>	<b>STM16o J0 Path Trace Message</b>
<b>26</b>	<b>J1 Path Trace Message</b>
<b>27</b>	<b>J2 Path Trace Message</b>
<b>28-35</b>	<b>SDH Error Add[RATE]/Detection</b>
<b>36-44</b>	<b>SDH Single Error Add/Detection</b>
<b>45</b>	<b>STM-16o Entire Frame Error Add/Detect</b>
<b>46</b>	<b>A1A2 Frame Error Add</b>
<b>47-49</b>	<b>PDH Payload Error Add[RATE]/Detection</b>
<b>50-52</b>	<b>PDH Payload Single Error Add/Detection</b>
<b>53-67</b>	<b>Alarm Generation/Detection</b>
<b>68-69</b>	<b>OOB Alarm Generation/Detection</b>

## Installation

### Self Tests

<b>70</b>	<b>TU-3/TU12 Mixed Payload Test</b>
<b>71</b>	<b>TU-12/TU-3 Mixed Payload Test</b>
<b>72</b>	<b>TU-3/TU-11 Mixed Payload Tests</b>
<b>73</b>	<b>TU-11/TU-3 Mixed Payload Tests</b>
<b>74-75</b>	<b>AU New Pointer Test</b>
<b>76-77</b>	<b>AU Frequency Offset Pointer Moves</b>
<b>78-79</b>	<b>TU Frequency Pointer Moves</b>
<b>80-81</b>	<b>STM-16o 140Mb/s Payload VC Offset Test</b>
<b>82</b>	<b>TU-3 Background Pattern Test</b>
<b>83</b>	<b>DCC Port Test</b>
<b>84-87</b>	<b>Stress Test</b>
<b>88-89</b>	<b>Service Disruption Test</b>

Installation  
**Self Tests**

**JITTER Test (test time- approximately 20 minutes)**

These tests apply to HP 37718A option 204, 205, 206 only. Provides extensive tests of the PDH/SDH Tx/Rx Jitter sections. Note this test is run as part of ALL TESTS.

<u>Subtest</u>	<u>Test Function</u>
<b>1-50</b>	<b>Jitter Receiver Internal Loopback tests</b>
<b>51-100</b>	<b>Not used</b>
<b>101</b>	<b>STM-16 Optical Power Check</b>
<b>102</b>	<b>Not used</b>
<b>103-108</b>	<b>2Mb/s Tx/Rx Jitter Tests</b>
<b>109-114</b>	<b>8Mb/s Tx/Rx Jitter Tests</b>
<b>115-120</b>	<b>34Mb/s Tx/Rx Jitter Tests</b>
<b>121-126</b>	<b>140Mb/s Tx/Rx Jitter Tests</b>
<b>127-150</b>	<b>Not used</b>
<b>151-156</b>	<b>STM1e Tx/Rx Jitter Tests</b>
<b>157-162</b>	<b>STM1o Tx/Rx Jitter Tests</b>
<b>163-168</b>	<b>STM-4 Tx/Rx Jitter Tests</b>
<b>169-174</b>	<b>STM-16 Tx/Rx Jitter Tests</b>
<b>175-177</b>	<b>Wander Tests</b>
<b>178</b>	<b>Transfer Test 155 Electrical</b>
<b>179</b>	<b>Transfer Test STM-16</b>

**LONG GATING test (test time- approximately 6 Hours)**

This test performs an extended gating check of each SDH/SONET Optical rate to confirm error free operation. Test time at each rate is sufficient to ensure that the error ratio is less than 1 in  $10^{12}$ . The test does NOT form part of ALL TESTS.

<u>Subtest</u>	<u>Test Function</u>
<b>1</b>	<b>Tx/Rx STM-0o with Bulk <math>2^{23}</math> Payload</b>
<b>2</b>	<b>Tx/Rx STM-1o with Bulk <math>2^{23}</math> Payload</b>
<b>3</b>	<b>Tx/Rx STM-4o with Bulk <math>2^{23}</math> Payload</b>
<b>4</b>	<b>Tx/Rx STM-16o with Bulk <math>2^{23}</math> Payload</b>

# Installation Self Tests

## LOOPBACKS REQUIRED BY TEST

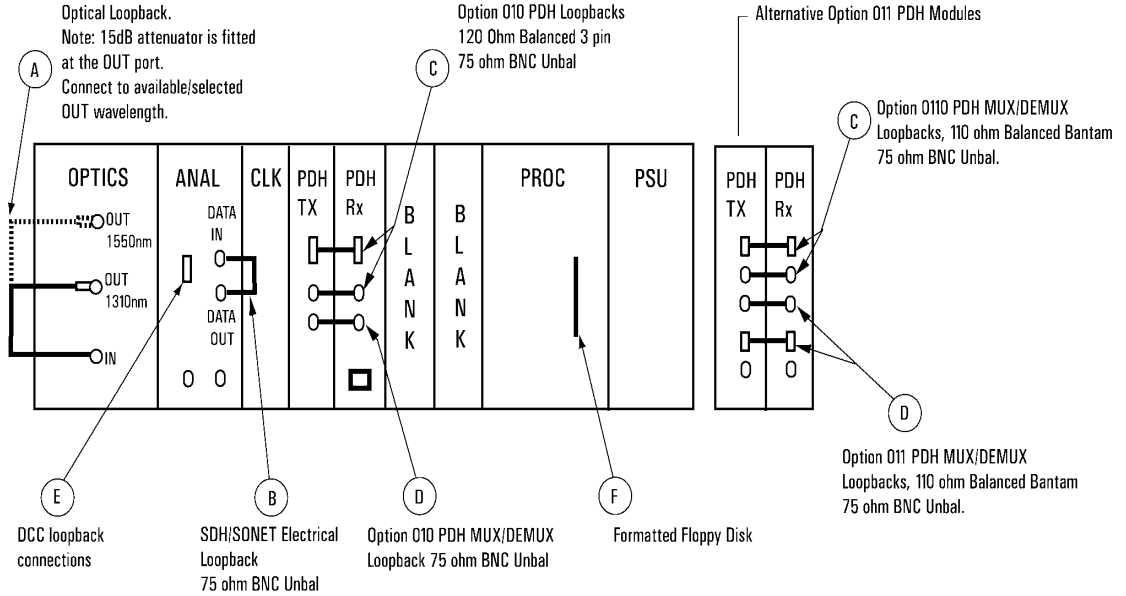

TEST	A	B	C	D	E	F
CONF	X	X	X			
ALL	X	X	X	X		X
CPU						X
PDH			X	X		
BER	X	X			X	
JITTER	X	X	X			
LONG GATING	X					

A HP E4545A 3m fibre optic cable FC/CP connections  
HP E4546A FC/CP 15db attenuator

B HP 15525A 75ohm BNC

C HP 15512A Siemens 3pin (Option 010 units)  
HP 15525A 75 ohm BNC  
HP 15670A Bantam 110 ohm (Option 011 units)

D HP 15552A 75 ohm BNC  
HP 15670A Bantam 110 ohm (Option 011 units)

E DCC 15 pin Loopback plug (pin 9 linked to 11)  
(pin 2 linked to 4)

F Formatted (Floppy Disk)

## **SELF TEST ERRORS**

The Tests will halt if a Self Test Error is detected. A message indicating the test point being run and error detected is displayed. Check all loopback connections and re-run the test. If the problem persists and contact your local HP Service Office or representative. Tests should only performed in a stable ambient environment where the instrument will not be disturbed during test.

The Self Test Error code numbering uses the following numeric format.

First Number indicates the Test being run.

CPU                    1xxx

CONFIDENCE. 2xxx

PDH                    3xxx (for Subtests < 100), 18xxx (for Subtests 100+)

BER                    4xxx

JITTER                5xxx (for Subtests<100, 20xxx (for Subtests 100+)

LONG GATING 6xxx

Note ALL TESTS uses the number from the tests it calls.

The next digits indicate the Subtest, e.g. 415x, is Subtest 15 of Test 4 (BER).

(where subtests are >99 the numbering restarts)

The last digit indicates the error type. In general these are -

1 = Loss of Signal

2 = specific for subtest

3 = test result too low

4 = test result too high

5 = loss of frame sync

6 = loss of pointer sync

7 = loss of pattern sync

The error codes are accompanied by appropriate error messages.

# 6

## Option Structure/Module Configuration

### Option Structure/Module Configuration

This section gives an overview of the HP 37718/9A Multirate SDH/SONET 2.5 Gb/s Option structures and Module configurations.

### SDH/SONET Operation Interface Options

- HP 37718A      Option 001 - SDH version
- HP 37718A      Option 002 - SDH/SONET version
- HP 37719A      SONET only

### PDH/Dsn Options

- HP 37718A      Option 010 - PDH rates 2/8/34/140Mb/s
- HP 37718/9A    Option 011 - Dsn/PDH rates DS1/DS3/E1/E3

### SDH/SONET 2.5Gb/s Multirate BER Options

- HP 37718/9A    Option 104 - 1310nm Optical TX
- HP 37718/9A    Option 105 - 1550nm Optical TX
- HP 37718/9A    Option 106 - 1313/1550nm Optical TX

### SDH/PDH Multirate BER + Jitter Options

- HP 37718A      Option 204 - 1310nm Optical TX
- HP 37718A      Option 205 - 1550nm Optical TX
- HP 37718A      Option 206 - 1313/1550nm Optical TX

# Installation

## 37718A/19A Multirate BER configurations - Options 104/105/106

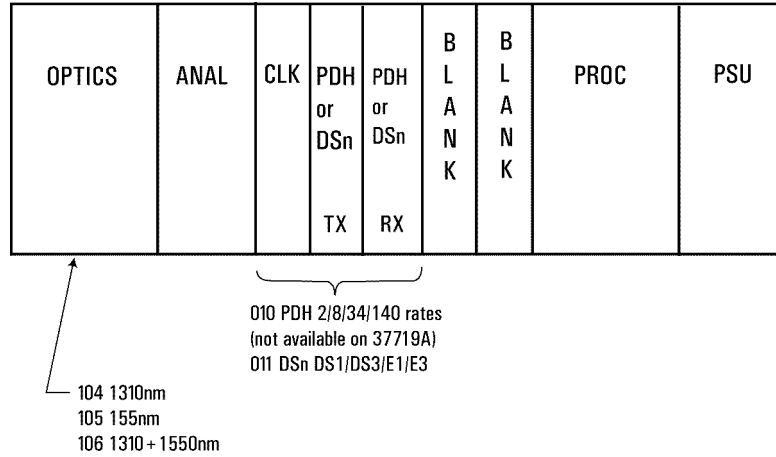

## 37718A Multirate BER + JITTER configurations - Options 204/205/206

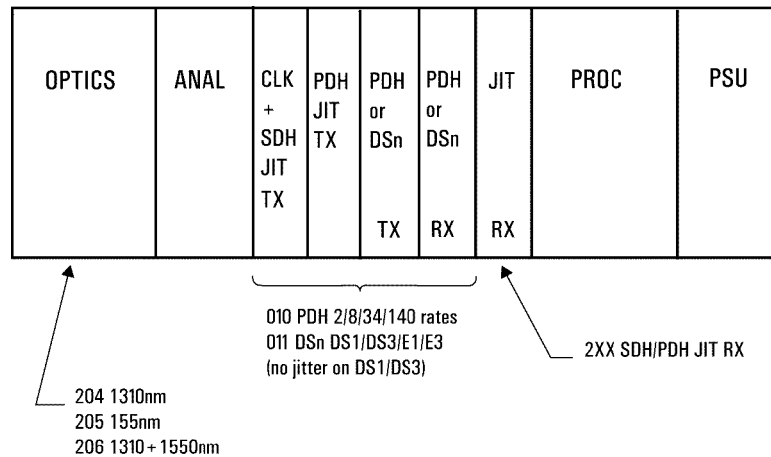



---

# Index

---

## Numerics

1.5M REF IN, 2-7  
2M REF IN, 2-7  
52/155 Mb/s DATA IN, 2-7  
52/155 Mb/s DATA OUT, 2-7  
64k REF IN, 2-7

## A

Accessories  
  Connection, 2-11  
Alternative External MTS Clock, 3-64  
Assistance, 1-3  
Australian EMC Regulations  
  Compliance with, 1-10

## C

Cabinet Cleaning, 1-8  
Certification, 1-3  
Cleaning, 1-8  
  Cabinet, 1-8  
  Optical Connectors, 1-8  
CLOCK TRIGGER, 2-8  
Compliance, Statement of, 1-10  
Connecting  
  Accessories, 2-11  
  ESD Precautions Necessary, 2-6  
  To the Network, 2-6  
  To the Power Supply, 2-4  
Connectors  
  Electrical Interface, 2-6  
  Optical Interface, 2-9

## D

DEMUX 2 Mb/s 75 ohm Connector, 2-7  
DEMUX DS1 100 ohm Connector, 2-7  
Dimensions and Weight, 1-5  
DS1 100 ohm, 2Mb/s 120 ohm IN Connector, 2-7  
DS1 100 ohm, 2Mb/s 120 ohm OUT, 2-7  
DS3, 2Mb/s, 34Mb/s 75 ohm IN Connector, 2-6  
DS3, 2Mb/s, 34Mb/s 75 ohm OUT Connector, 2-6

## E

Electrical Interface Connectors, 2-6  
Electromagnetic Compatibility, 1-11  
Electrostatic Discharge, 1-11

## Environment

  Operating, 2-2  
  Storage and Shipment, 1-4  
ESD Precautions  
  For the Service Engineer, 2-6, 2-14  
External 2Mb/s Mux/Demux, 3-44  
External MTS Clock, 3-59

## F

Fuse Replacement, 2-3  
Fuses, 2-3

## H

HANDSET Connector, 2-11  
Hewlett-Packard Interface Bus, 2-12  
HP-IB, 2-12  
  Address Selection, 2-13  
  Connections, 2-13  
HP-IB Address, 2-13  
HP-IB Connection, 2-12

## I

Inspection, Initial, 2-1  
Instruments Covered By Manual, 1-4  
Internal SDH Transmitter Clock, 3-58

## J

Jitt. Amp. PDH Tx/Rx, 89  
Jitt. Amp. SDH Tx/Rx, 101

## L

Laser apertures  
  Location, 2-10  
LID Connector, 2-11  
Lifting/Carrying the Instrument, 1-6  
Location of Laser Apertures, 2-10

## M

Maintenance by the Operator, 1-8  
MUX 2 Mb/s 75 ohm Connector, 2-7  
MUX Connector, 2-7  
MUX DS1 100 ohm Connector, 2-7

## N

Noise Declaration (German), 1-10

## O

Operators Maintenance, 1-8

Optical Connector Cleaning, 1-8  
OPTICAL IN Connector, 2-10  
Optical Interface Connectors, 2-9  
OPTICAL OUT Connector, 2-10

## P

PDH Frequency Measurement and Looped Clock, 3-54, 3-57  
PDH Receiver Equalization, 3-32, 3-75  
PDH Tx/Rx Jit. Amp., 89  
Performance Test Record, 121, 131  
Power Cord, 2-5  
Power Requirements, 2-3  
Power Supply Connection, 2-4  
Precautions  
  ESD when connecting, 2-6  
  Precautions for the Service Engineer, 2-14  
  Preparation for Use, 2-3  
Printer HP-IB, RS232, PARALLEL ONLY Connector, 2-11

## R

Recall Default Settings, 3-4  
RECEIVER 2,8,34,140 IN, 2-6  
Recommended Test Equipment, 3-5  
REF OUT, 2-7  
Remote Control HP-IB, RS232, 10 BASE -T Connector, 2-11  
Repackaging, 1-4  
Responsibilities of the Customer, 1-2  
Restricted Rights Legend, 1-3

## S

Safety Information, 1-6  
Safety Precautions  
  For the Operator, 1-6  
  For the Service Engineer, 2-14  
Safety Symbols, 1-7  
SDH Frequency Offsets, 3-64, 3-65  
SDH Tx/Rx Jitt. Amp., 101  
Self Test, 3-5  
Serial Number Plate, 1-4  
Shipping Container Inspection, 2-1  
SPDH Receiver Monitor Levels, 3-39, 3-78  
Statement of Compliance, 1-10  
STM-1 Transmitter Output Waveshape, 3-66, 3-70

---

# Index

---

STM-1/STM-4 Optical Interface, 3-82  
Storage and Shipment, 1-4  
Symbols, Safety, 1-7

**T**  
TRANSMIT 2,8,34,140 OUT, 2-6

**V**  
VGA Connector, 2-11

**W**  
warning symbols, 2-10  
Warranty, 1-1  
Weight and Dimensions, 1-5

# Hewlett-Packard Sales and Service Offices

The following information was correct at the time of printing. If you have difficulty contacting an HP office, an up-to-date list of contacts is available through the HP Website at URL <http://www.tmo.hp.com/tmo/index.html>.

## ***Austrailia/New Zealand***

### ***Australia:***

Hewlett-Packard Australia Ltd.

31-41 Joseph Street

PO Box 221

Blackburn, Victoria 3130

Phone Number: 1-800-629-485

Fax: (61-3) 9272-0749

### ***China:***

China Hewlett-Packard Co. Ltd.

HP Building

No. 2, dong San Huan Nan Lu

Chao Yang District

Beijing 100022, PRC

Phone Number: (86-10) 6564-3888, 800-810-0189

Fax: (86-10) 6566-8250

### ***India:***

Hewlett-Packard India

Telesales Engineer

Test & Measurement

Chandiwala Estate, Kalkaji

New Delhi - 110019

E-mail HPI Test & Measurement Telesales

Phone Number: (91/11)6906156 /6826262

or 6826000 ext. 6156

Fax: (91/11)6826027

### ***Korea, Republic of:***

Hewlett-Packard Korea Ltd.

25-12, Yoido-dong

Youngdeungpo-ku

Seoul, 150-010

Phone Number: (82-2) 769-0800

Fax: (82-2) 786-1083

### ***Malaysia:***

Hewlett-Packard Sales (M) Sdn Bhd

HP DIRECT Test and Measurement

Ground Floor, Wisma Cyclecarri

288, Jalan Raja Laut

50350 Kuala Lumpur

Malaysia

Phone Number: 1-800-88-8848

(6-03) 291-0213

Fax: (6-03) 298-9157

E-Mail Address: hp-direct\_my@hp.com

### ***New Zealand:***

Hewlett-Packard (New Zealand) Ltd.

186-190 Willis Street

PO Box 9443

Wellington

Phone Number: 0800-738-378

Fax: 64-4-802-6881

### ***Singapore:***

Hewlett-Packard Singapore (Sales) Pte Ltd.

450 Alexandra Road

Singapore 119960

Phone Number: 1800 3758100

Fax: (65) 275-9841

E-Mail Address: hpdirect\_sgp@hp.com

# Hewlett-Packard Sales and Service Offices (continued)

## ***Taiwan:***

Hewlett-Packard Taiwan Ltd.  
Hewlett-Packard Building  
8/F No. 337 Fu-Hsing North Road  
Taipei, 105  
Phone Number: 080-212-535  
Fax: (886-2) 2718-9860  
HP DIRECT Basic Tools toll free: 0800-47866,

## ***Thailand:***

Hewlett-Packard (Thailand) Ltd.  
23rd-25th floor Vibulthani Tower 2  
3199 Rama IV Road  
Klong Toey, Bangkok 10110  
Phone Number: 661-3999, (088) 225-802

## ***Europe***

### ***Austria:***

Hewlett-Packard GmbH  
HP DIRECT Österreich  
Herrenberger Str. 110-140  
D-71034 Böblingen  
Deutschland  
aus Österreich  
Phone Number: (01) 25000-7171  
Fax: (01) 25000-7172  
E-Mail Address: Messtechnik\_vertrieb@hp.com

### ***Belgium:***

Hewlett-Packard Belgium SA/NV  
Test & Measurement  
Boulevard de la Woluwe 100-102  
B-1200 Brussels  
Phone Number: (32/2) 778 3417  
Fax: (32/2) 778 3414

## ***Czech Republic:***

T&M DIRECT, s.r.o.  
Technická 2  
166 27 Praha 6  
Phone Number: 420/2/2435 5808  
Fax: 420/2/2435 5809

## ***Denmark:***

Hewlett-Packard A/S  
T&M Direct  
Kongevejen 25  
3460 Birkerød  
Phone Number: 45 99-15-15  
Fax: 45 82-06-30  
E-Mail Address: test\_measurement@hp.dk

## ***Finland:***

Hewlett-Packard Oy  
Piispankalliontie 17  
02200 ESPOO  
Finland  
P.O. Box Address:  
P.O. Box 68  
02201 ESPOO  
Finland  
Phone Number: 358-9-8872 2100  
Fax: 358-9-8872 2923  
E-Mail Address: tmodirect@finland.hp.com

# Hewlett-Packard Sales and Service Offices (continued)

## **France:**

Hewlett-Packard France  
HP DIRECT  
Test et Mesure  
Z.A. de Courtaboeuf  
1, Avenue du Canada  
91947 Les Ulis Cedex  
Phone Number: 01 69 29 41 14  
Fax: 01 69 82 65 09

## **Germany:**

Hewlett-Packard GmbH  
HP DIRECT  
Herrenberger Str. 140  
71034 Böblingen  
Phone Number: (0180) 524-63 33  
Fax: (0180) 524-63 36  
E-Mail Address: Messtechnik\_vertrieb@hp.com

## **Greece:**

HP DIRECT  
G-SYSTEMS  
76, Ymittou Street  
11634 Athens  
Phone Number: 01 726 40 26  
Fax: 01 726 40 20

## **Ireland:**

Hewlett-Packard Ireland Ltd.  
HP DIRECT  
Hewlett-Packard House  
Stradbroke Road  
Blackrock Co.  
Dublin  
Phone Number: 01 615 8222  
Fax: 01 284 5134

## **Italy:**

Hewlett-Packard Italiana S.p.A.  
HP DIRECT  
Soluzioni di Misura e Collaudo  
Via G. Di Vittorio, 9  
20063 Cernusco s/N (MI)  
Phone Number: 39 02 9212 2241  
Fax: 39 02 9210 4069  
E-Mail Address:  
hpi\_direct@hp-italy-gen3.om.hp.com

## **Netherlands:**

Hewlett-Packard Nederland B.V.  
HP T&M DIRECT  
Startbaan 16  
1187 XR Amstelveen  
Phone Number: 020-547 6669  
Fax: 020-547 7765  
E-Mail Address:  
tmdept\_hpnl@hp-netherlands-gen1.om.hp.com

## **Norway:**

Hewlett-Packard Norge A/S  
T&M Direkte Drammensveien 169  
Postboks 60 Skoeyen 0212 OSLO  
Norway  
Phone Number: +47 2273 5759  
Fax: +47 2273 5619  
E-Mail Address:  
test\_measurement@norway.hp.com

## **Poland:**

Malkom  
Ul. Bodycha 18  
02-495 Warszawa  
Phone Number: 48-22-7230066  
Contact: Beata Sniecikowska

# Hewlett-Packard Sales and Service Offices (continued)

## ***Spain:***

Hewlett-Packard Española, S.A.  
HP DIRECT  
Ctra. N-VI, KM 16,500  
28230 Las Rozas, Madrid  
Phone Number: 34 91 631.13.23  
Fax: 34 91 631.14.69

## ***Sweden:***

Hewlett-Packard Sverige AB  
HP Test & Mät-systems kundcenter  
Skalholmsgatan 9  
S-164 97 KISTA  
Sweden  
Phone Number: (08) 444 2277  
Fax: (08) 444 2525  
E-Mail Address:  
test-measurement@sweden.hp.com

## ***Switzerland:***

Hewlett-Packard (Schweiz) AG  
HP DIRECT Schweiz  
Elektronische Meßtechnik  
In der Luberzen 29  
8902 Urdorf/Zürich  
German speaking:  
Phone Number: (01) 735 72 00  
Fax: (01) 735 72 90  
French speaking:  
Tel: (022) 780 4361  
Fax: (022) 780 4180  
E-Mail Address: Messtechnik\_vertrieb@hp.com

## ***United Kingdom:***

Hewlett-Packard Ltd.  
Test & Measurement  
Cain Road

Bracknell, Berkshire  
RG12 1HN  
Phone Number: 01344-366666  
Fax: 01344-362852  
E-Mail Address: uktmo\_sales@hp.com

## ***Japan:***

Hewlett-Packard Japan Ltd.  
Measurement Assistance Center  
9-1, Takakura-Cho, Hachioji-Shi  
Tokyo, 192-8510  
Phone Number: 81-426-56-7832  
Additional phone number(s): 0120-421-345  
Fax: 81-426-56-7843  
Additional Fax: 0120-421-678

## ***Latin America***

### ***Brazil:***

Hewlett-Packard Brasil S.A.  
Depto. Teste e Medicao  
Alameda Rio Negro, 750  
06454-000-Alphaville-Barueri  
Sao Paulo, Brazil  
Phone Number: (55-11) 7297-8600  
Fax: (55-11) 7297-8171

### ***Mexico:***

Hewlett-Packard de Mexico, S.A. de C.V.  
Prolongacion Reforma No. 700  
Col. Lomas de Santa Fe  
01210 Mexico D.F.  
Phone Number: (52-5) 258-4392  
Fax: (52-5) 258-4301  
HP DIRECT: 01 800 50648

# Hewlett-Packard Sales and Service Offices (continued)

## ***Middle East and Africa***

### ***Israel:***

HP DIRECT

C.M.S. LTD.

11, Hashelosh St.

Tel-Aviv 67060

Phone Number: 03 53 80 377

Fax: 03 53 76 505

Hewlett-Packard

HP DIRECT

11, Hashlosa St.

Tel-Aviv 67060

Phone Number: 03 53 80 377

Fax: 03 53 76 505

### ***South Africa:***

Hewlett-Packard South Africa (Pty.) Ltd.

HP DIRECT

Private Bag

WENDYWOOD 2148

Phone Number: 27-11-806 1173

Fax: 27-11-806 1213

## ***North America***

### ***Canada:***

Hewlett-Packard (Canada) Ltd.

HP DIRECT

5150 Spectrum Way

Mississauga, ON

L4W 5G1

Phone Number: 1-877-894-4414

Fax: 1-(905) 206-4700

Hewlett-Packard (Canada) Ltd.

Test & Measurement Business Centre

2670 Queensview Drive

Ottawa, Ontario K2B 8K1

Phone Number: 1-800-276-8661

Fax: 1-800-746-4866

### ***United States:***

#### ***For Technical Product Information***

Hewlett-Packard Co.

Test & Measurement Call Center

9780 S. Meridian Blvd.

Englewood, CO 80112

Phone Number: (800) 452-4844

Fax: (303) 662-3726

#### ***For Quotation/Order Information:***

Hewlett-Packard Co.

Test & Measurement Business Center

9780 S. Meridian Blvd.

Englewood, CO 80112

Phone Number: (800) 829-4444

Fax: (800) 829-4433

#### ***For Federal Government Orders:***

Hewlett-Packard Co.

P.O.Box 1487

Rockville, MD 20849-1487

Phone Number: (800) 468-8347

Fax: (800) 437-1085

### ***California***

Hewlett-Packard Co. (2451)

301 E. Evelyn Avenue

Mountain View, CA 94041

Phone Number: (800) 403-0801

Fax: (888) 857-8161

Hewlett-Packard Co. (24BR)

10090 Foothill Blvd.

## **Hewlett-Packard Sales and Service Offices (continued)**

Roseville, CA 95747-7102

Phone Number: (800) 403-0801

Fax: (888) 857-8161

### ***Colorado***

Hewlett-Packard Co. (2452)

24 Inverness Place East

Englewood, CO 80112

Phone Number: (800) 403-0801

Fax: (888) 857-8161

### ***New Jersey***

Hewlett-Packard Co. (4401)

150 Green Pond Road

Rockaway, NJ 07866

Phone Number: (800) 403-0801

Fax: (888) 857-8161

### ***Texas***

Hewlett-Packard Co. (3185)

930 E. Campbell Road

Richardson, TX 75081

Phone Number: (800) 403-0801

Fax: (888) 857-8161



---

## **About This Edition**

This is the first edition of the 37718-90069 manual. It documents the product as of 05/99. Edition dates are as follows:

First Edition May 99.

© Copyright Hewlett-Packard Ltd. 1999

All rights reserved. Reproduction, adaption, or translation without prior written permission is prohibited, except as allowed under the copyright laws.

**In This Book**

This book contains installation information and techniques for checking instrument specifications.

